

## Description

The SQ6601PT is a hybrid IC consists from power MOSFET and a controller IC, designed for Indirect feed-back Quasi-Resonant (including low frequency PRC) fly-back converter type SMPS (Switching Mode Power Supply) applications. this IC realizes high efficiency, low noise, downsizing and standardizing of a power supply system reducing external components count and simplifying the circuit designs. the device is provided in a five pin over-molded TO-220 style package, affording dielectric isolation without compromising thermal characteristics.

(Note). PRC is abbreviation of "Pulse Ratio Control" (On-width control with fixed OFF-time).

## Features

- Quasi-Resonant Operation
- Low-loss, Pulse-Ration-Control standby mode
- Under-voltage lockout with Hysteresis
- Adjustable switching speed for EMI control
- Low start-up circuit current (100uA max)
- Active low-pass filter for stabilizing the operation in case of light load
- Avalanche Energy Guaranteed MOSFET with high VDSS
- Built-in constant voltage drive circuit
- Built-in step drive circuit
- Built-in low frequency PRC mode ( $\approx 20\text{kHz}$ )
- Pulse-by-pulse Overcurrent Protection (OCP)
- Overvoltage Protection with latch mode (OVP)
- Thermal Shutdown with latch mode (TSD)
- Over-molded Five-Pin Package

## Ordering Information

Type NO.	Marking	Package Code
SQ6601PT	SQ6601PT	TO-220F-5FL

## Package Outline

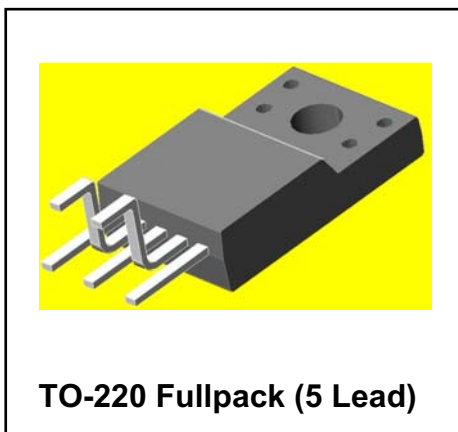

## Internal Block Diagram

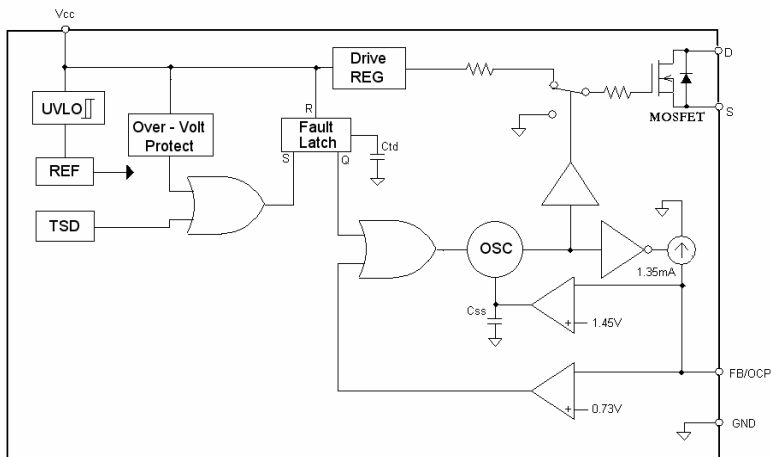

## Pin Function

Pin Number	Pin Name	Pin Function
1	Drain	Power Switch MOSFET Drain Part
2	Source	Power Switch MOSFET Source Part
3	GND	Ground of the Control Section
4	Vcc	Supply Voltage of Output Drive & Control Section
5	FB/OCP	Voltage Mode Control Feedback Signal & Over Current Detection

## Typical Connection Diagram

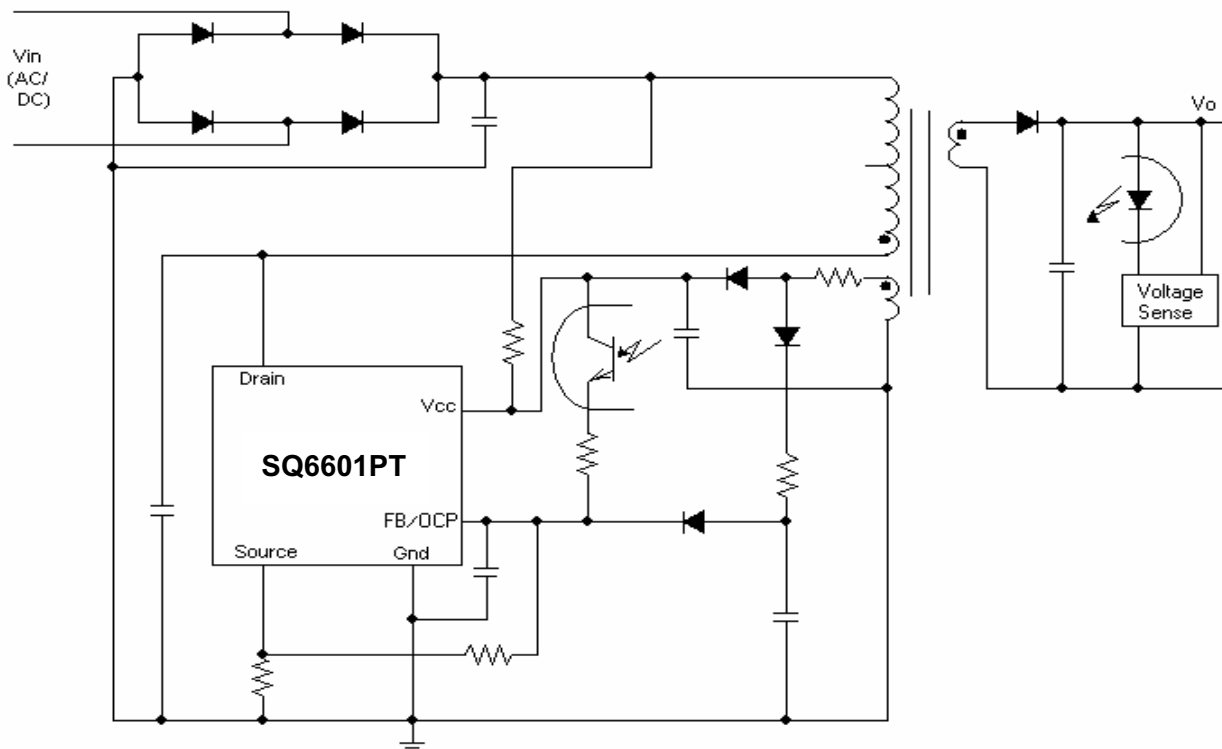

## Absolute maximum ratings

(Ta=25°C, Unless otherwise specified)

Characteristic	Symbol	Ratings	Unit	Note
Drain Source Voltage	$V_{DS}$	650	V	-
Drain Current	$I_D$	7	A	$T_C = 25^\circ\text{C}$
Peak Drain Current	$I_{DP}$	28	A	Single Pulse
Single Pulsed Avalanche Energy	$E_{AS}$	640	mJ	$L=23\text{mH}, V_{DD}=100\text{V}, I_{DP}=7.0\text{A}$
Control Supply Voltage	$V_{CC}$	20	V	-
FB/OCP Voltage Range	FB/OCP	-0.3 ~ +6	V	-
Power Dissipation	$P_D$	40	W	With infinite heatsink
Thermal Resistance, Junction to Case	$R_{thJC}$	3.12	$^\circ\text{C}/\text{W}$	-
Junction Temperature	$T_J$	150	$^\circ\text{C}$	-
Operating Temperature Range	$T_{opr}$	-25 ~ +125	$^\circ\text{C}$	-
Storage Temperature Range	$T_{stg}$	-55 ~ +150	$^\circ\text{C}$	-

## Recommended Operating Conditions

Time for input of quasi resonant signals.

For the Quasi resonant signal inputted to the  $V_{FB/OCP}$  terminal at the time of quasi resonant operation, the signal should be wider than  $T_{th}(2)$

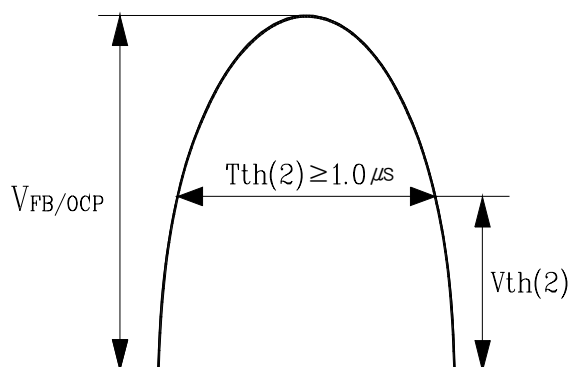

## Electrical Characteristics

( $V_{CC} = 11V$ ,  $T_a = 25^{\circ}C$  ; Unless otherwise specified)

Characteristic	Symbol	Test Conditions	Min.	Typ.	Max.	Units
Start Threshold Voltage	$V_{TH(ST)}$	$V_{CC}$ Increasing	8.5	9.5	10.5	V
Stop Threshold Voltage	$V_{TH(SP)}$	$V_{CC}$ decreasing after turn on start threshold voltage	7.2	8	8.8	V
Start up Supply Current	$I_{ST}$	$V_{CC} = V_{TH(ST)} - 0.1V$	-	-	100	$\mu A$
Operating Supply Current	$I_{CC}$	$V_{FB} = 1V$	-	3	7	mA
Dynamic Operating Supply Current	$I_{DCC}$	-	-	4	10	mA
Maximum Off Time	$t_{MAX}$	Drain waveform high	30	-	60	$\mu s$
Minimum Off Time	$t_{MIN}$	Drain waveform high	-	-	1.5	$\mu s$
Minimum Input Pulse Width	$t_{MIN(W)}$	Drain waveform high	-	-	1.0	$\mu s$
Over Voltage Threshold	$V_{OVP}$	$V_{CC}$ Increasing until shut down output	15.3	17	18.7	V
Latch Release Voltage	$V_{RE}$	$V_{CC}$ decreasing until latch releasing	2.5	-	6.0	V
Latch Holding Current	$I_{CC(RE)}$	-	-	-	400	$\mu A$
Feedback Threshold Voltage	$V_{FB}$	-	0.68	0.73	0.78	V
Css Synchronized Voltage	$V_{SYNC}$	-	1.3	1.45	1.6	V
Feedback Sink Current	$I_{SINK}$	$V_{FB} = 1V$	1.2	1.35	1.5	mA
Thermal Shutdown Activation Temperature	$T_{J(TSD)}$	-	140	-	-	$^{\circ}C$
Drain-to-Source Breakdown Voltage	$V_{DS}$	$I_D = 300\mu A$	650	-	-	V
Drain Leakage Current	$I_{DS}$	$V_{DS} = 650V$	-	-	300	$\mu A$
On-State Resistance	$R_{DS(ON)}$	$I_D = 3.5A$	-	-	1.2	$\Omega$
Rise Time	$t_r$	10% to 90%	-	-	250	ns

Electrical Characteristic Curves

Fig. 1  $I_{CC}$  vs.  $T_a$

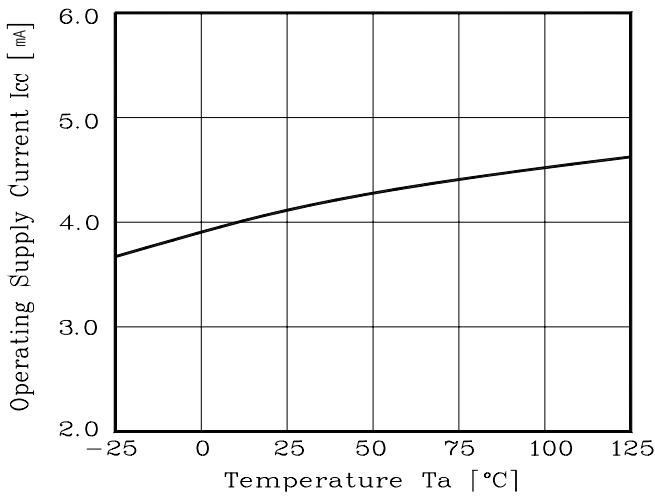

Fig. 2  $V_{TH(SP)}$  vs.  $T_a$

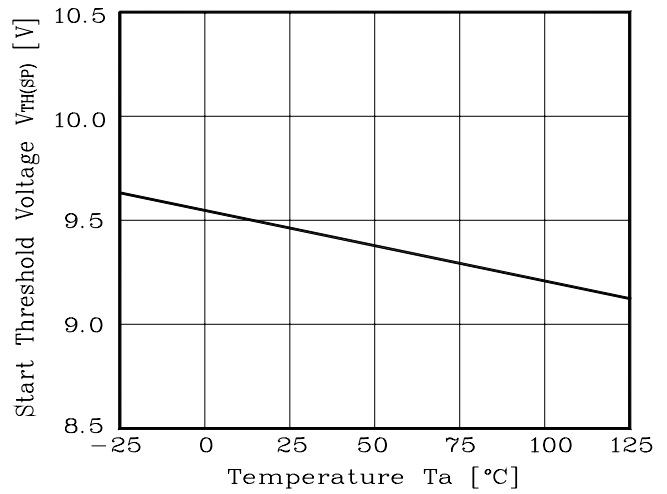

Fig. 3  $I_{ST}$  vs.  $T_a$

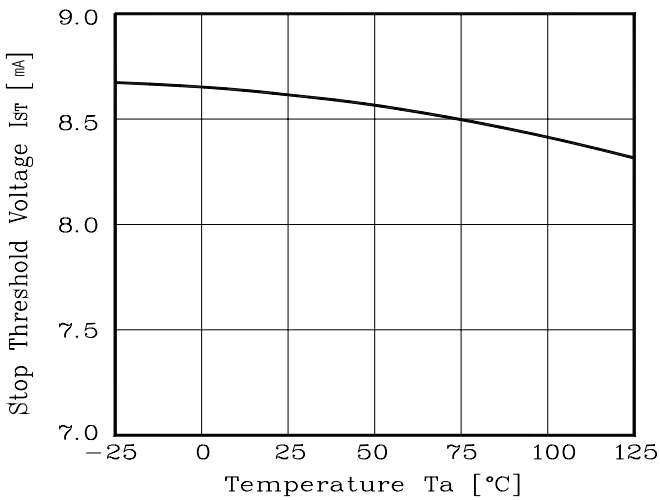

Fig. 4  $V_{FB}$  vs.  $T_a$

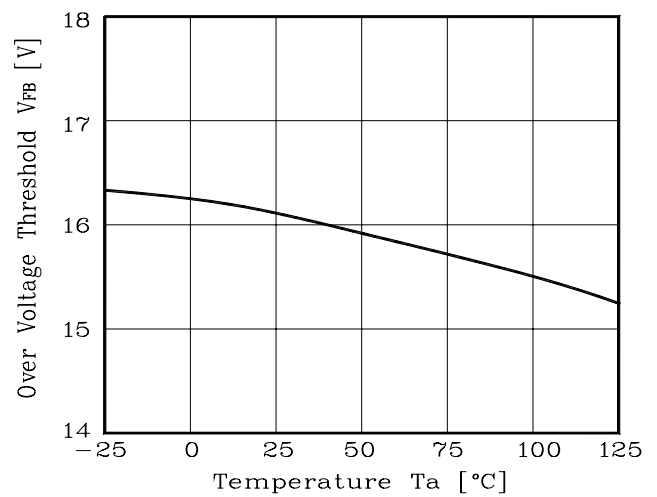

Fig. 5  $V_{TH(ST)}$  vs.  $T_a$

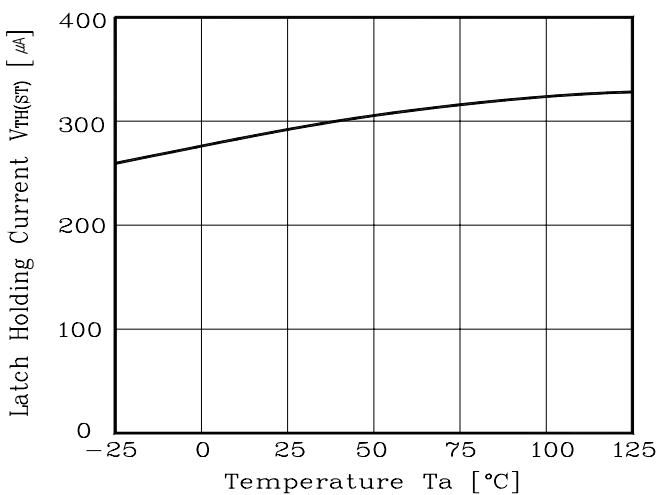
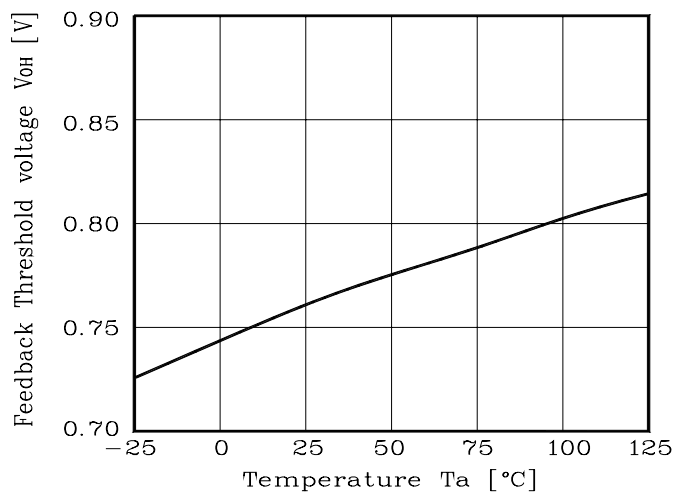

Fig. 6  $V_{OH}$  vs.  $T_a$



## Electrical Characteristic Curves

Fig. 7  $V_{OL}$  vs  $T_a$

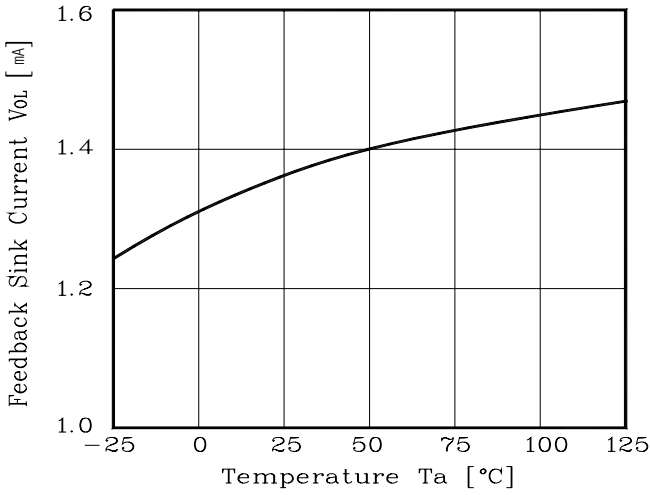

Fig. 8  $I_{CC}$  vs  $V_{th}$

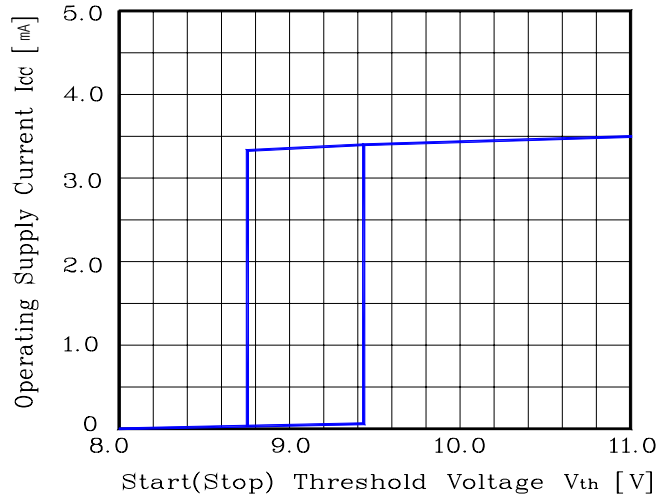

Fig. 8 Safe Operating Area

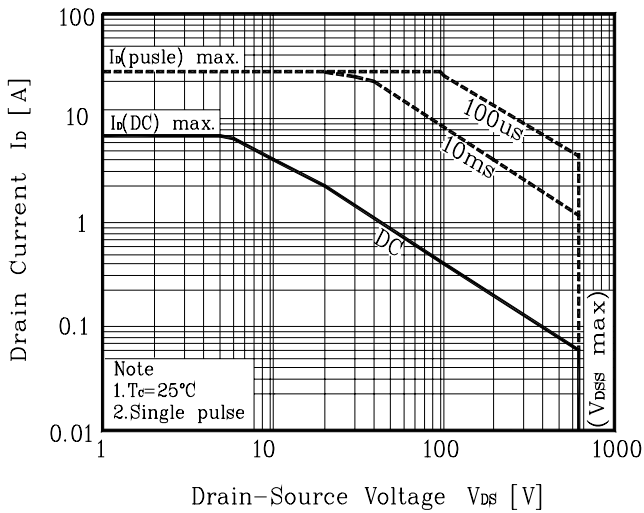

Fig. 9  $P_D$  vs  $T_c$

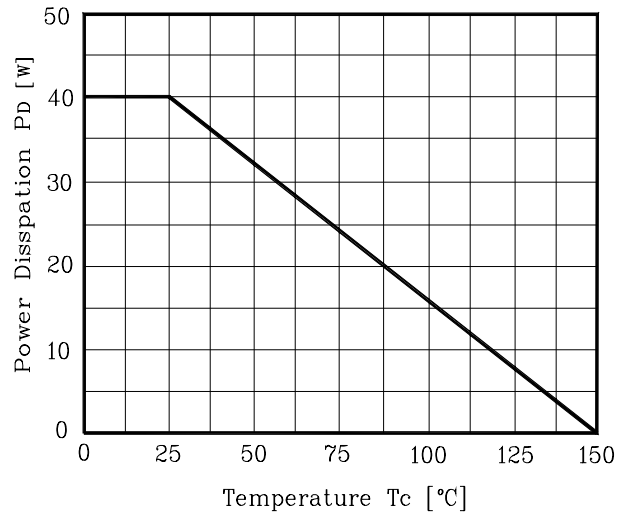
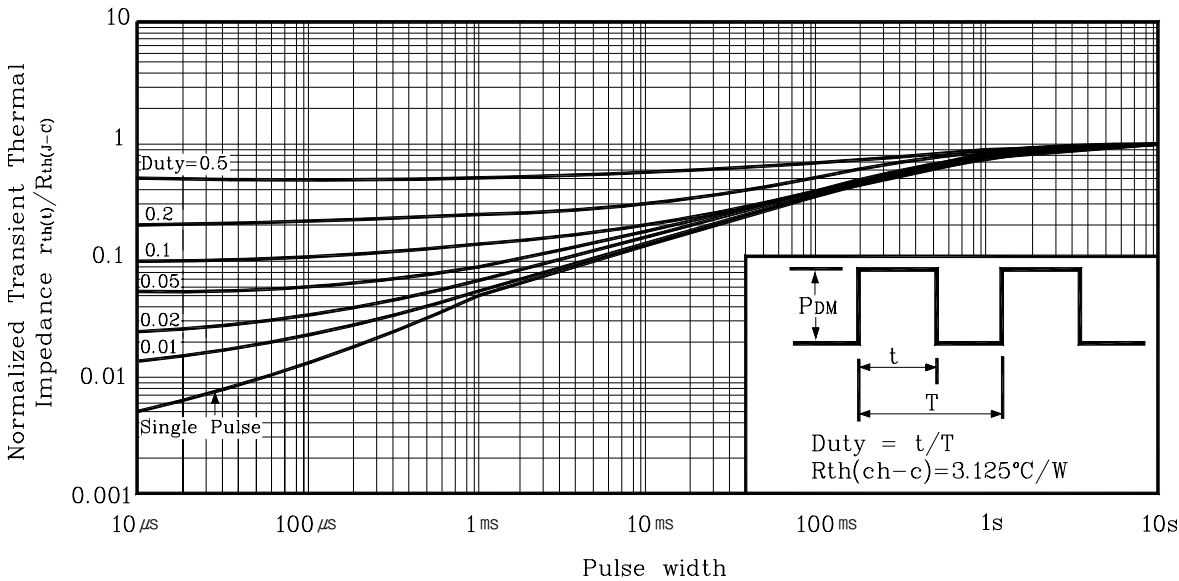
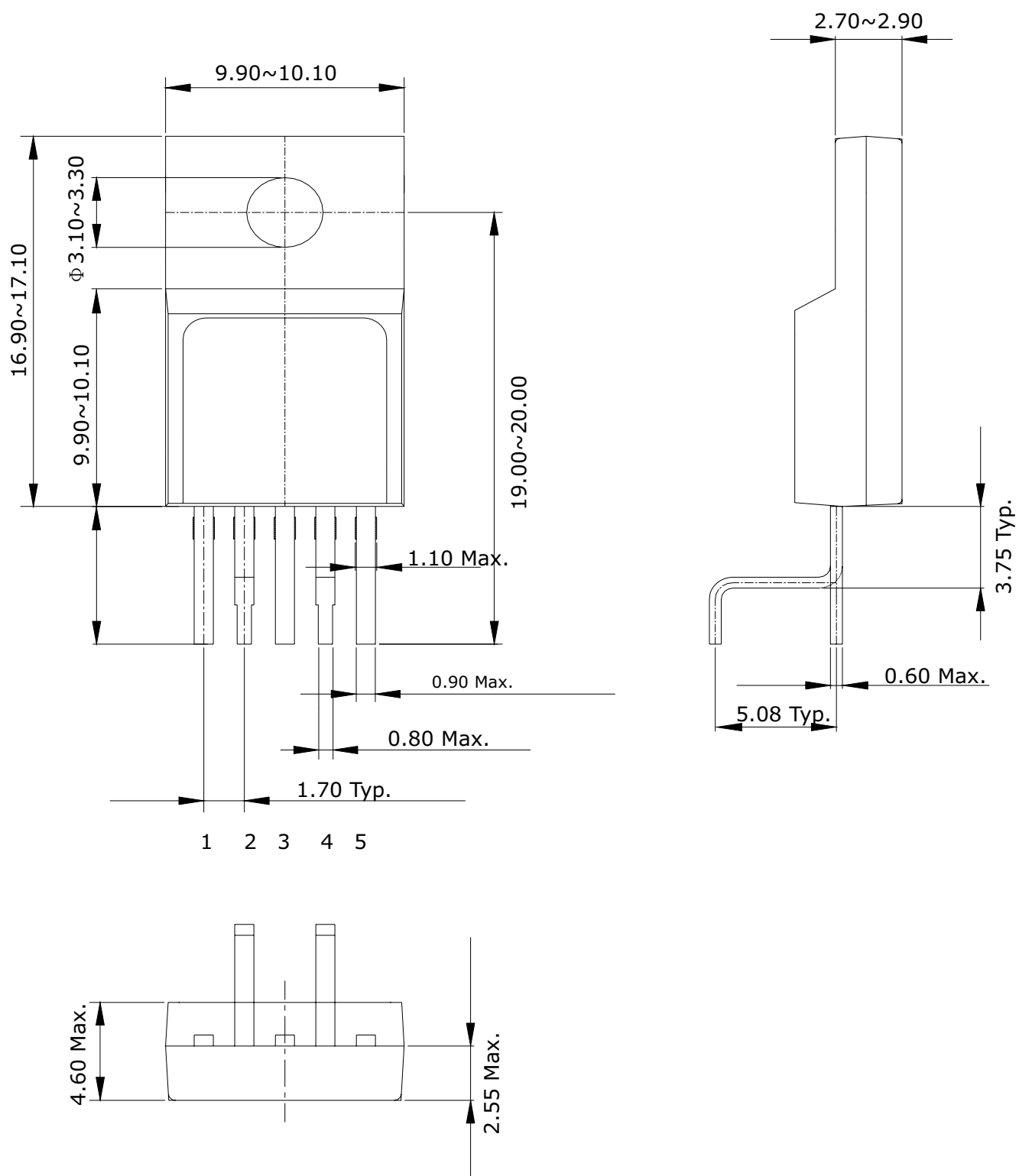

Fig. 10 Thermal Response



Outline Dimensions

unit : mm



**The AUK Corp. products are intended for the use as components in general electronic equipment (Office and communication equipment, measuring equipment, home appliance, etc.).**

**Please make sure that you consult with us before you use these AUK Corp. products in equipments which require high quality and / or reliability, and in equipments which could have major impact to the welfare of human life(atomic energy control, airplane, spaceship, transportation, combustion control, all types of safety device, etc.). AUK Corp. cannot accept liability to any damage which may occur in case these AUK Corp. products were used in the mentioned equipments without prior consultation with AUK Corp..**

**Specifications mentioned in this publication are subject to change without notice.**