

Descriptions

The S3842, high performance current mode controller, Provides the necessary features to off-line and DC-DC fixed frequency current control applications offering the designer a cost effective solution with minimal external components. Internally protection circuitry includes built-in input and reference under-voltage lockout and current limiting with hysteresis. Also other characteristics of internal circuit provide improved line regulation, enhanced load response, trimmed oscillation for precise duty cycle control, a temperature compensated reference, high gain error amplifier, current sensing comparator and totempole output designed to source and sink high peak current from a capacitive load such as the gate of a power MOSFET.

Features

- Optimized for off-line control
- Low start up and operating current
- Pulse by pulse current limiting
- Enhanced load response characteristic
- Current mode operation to 500 kHz
- Under voltage lockout with 6V hysteresis
- Internally trimmed bandgap reference about 5V
- Automatic feed forward compensation

Ordering Information

Type NO.	Marking	Package Code
S3842	S3842	SOP-8

Outline Dimensions

unit : mm

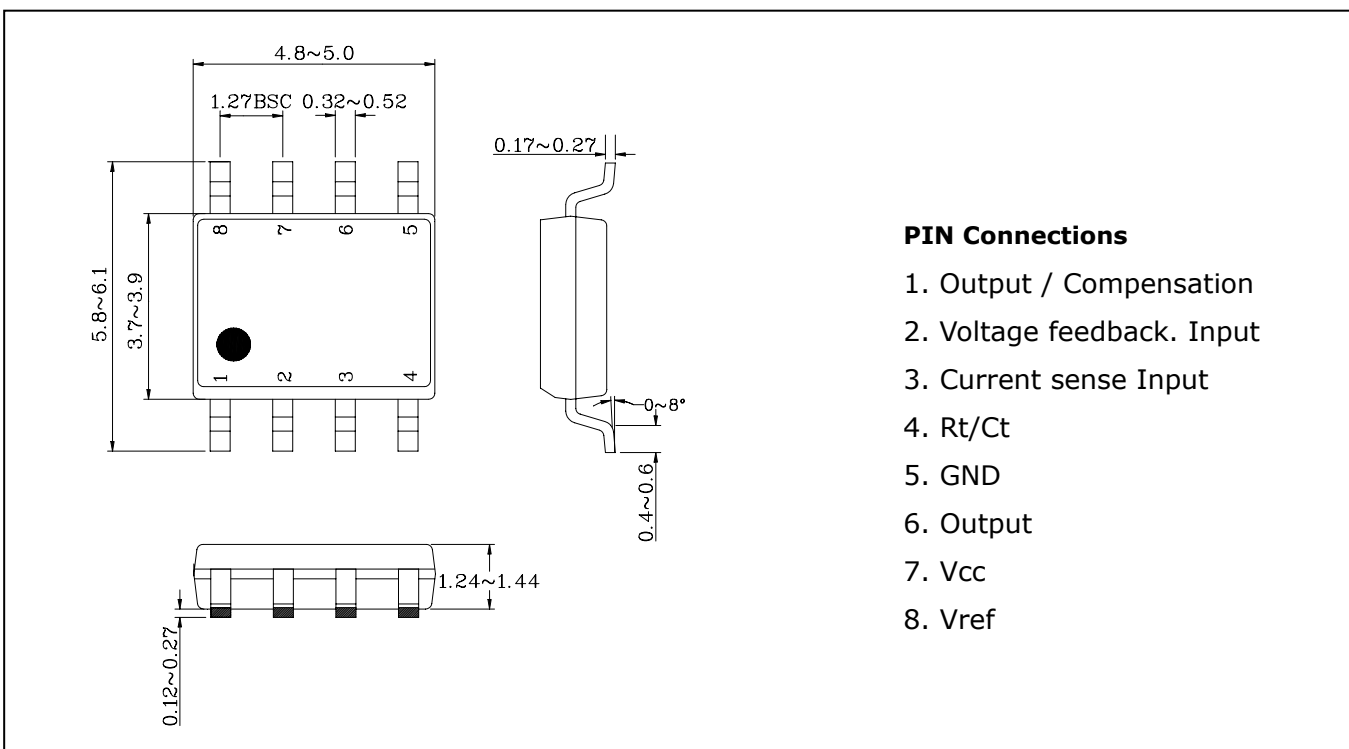

Absolute Maximum Ratings

T_a=25°C

Characteristic	Symbol	Ratings	Unit
Supply voltage	V _{CC}	30	V
Current Sense and V _{fb} Input	V _{IN}	-0.3 to V _{CC}	V
Total Power Supply and Zener Current	I _{CC} + I _Z	30	mA
Output Sink of Source Current	I _o	1	A
Error AMP Output Sink Current	I _{eo}	10	mA
Operating Ambient Temperature	T _a	0 to 70	°C
Storage Temperature Range	T _{stg}	-65 to 150	°C
Power Dissipation at T _a ≤ 50°C	P _d	1	W

note) All voltages are with respect to PIN5, and current are positive into the specified pin.

PIN Description

PIN NO	Function	Description
1	Compensation	Error amplifier output and is made available for loop compensation.
2	Voltage feedback	Inverting input of error amplifier, normally connected to the switching power supply output through a resistor driver.
3	Current sense	A voltage proportional to inductor current is connected to this input. The PWM uses this information to terminate the output.
4	R _t /C _t	The oscillator frequency and maximum output duty cycle are programmed by connecting resistor R _t to V _{ref} and capacitor C _t to ground.
5	Ground	This pin is the combined control circuitry and power ground.
6	Output	This output directly drives the gate of a power MOSFET. Peak current up to 1.0A are sourced and sunk by this pin.
7	V _{CC}	This pin is the positive supply of the control IC.
8	V _{ref}	This is the reference output. it provides charging current for capacitor C _t through resistor R _t .

Block Diagram

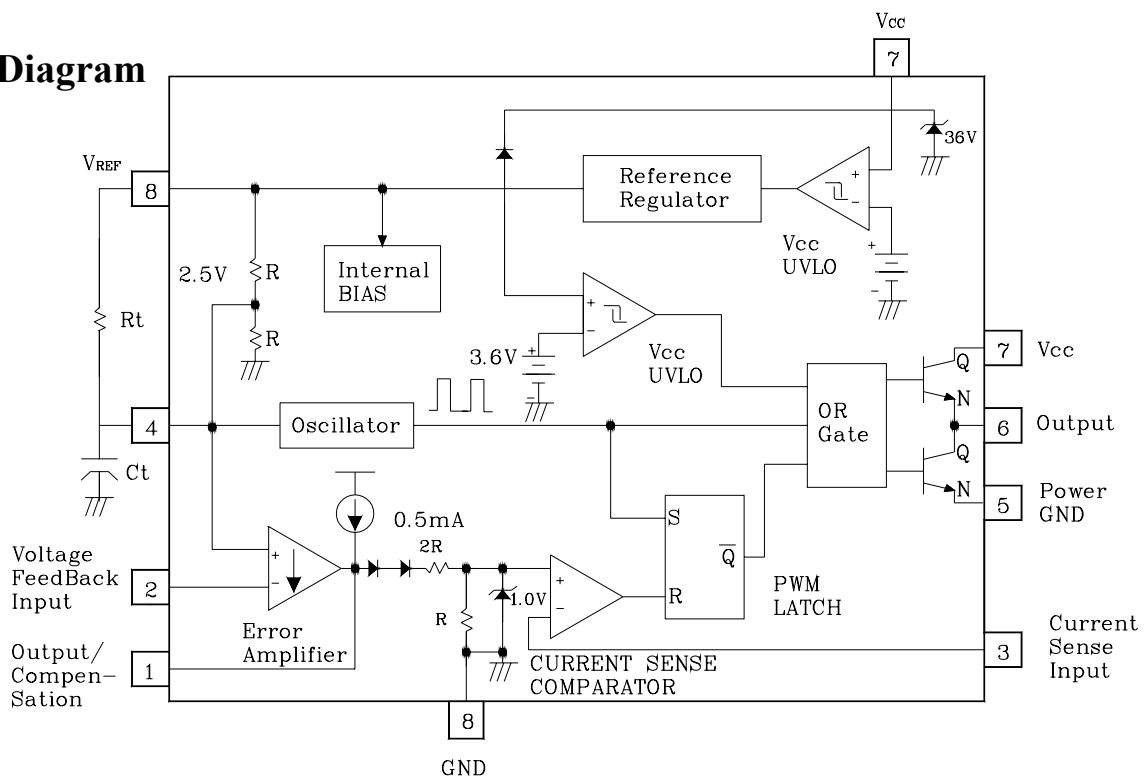

Electrical Characteristics

(Unless otherwise stated, these specifications apply for $0 \leq T_a \leq 70^\circ\text{C}$; $V_{CC} = 15\text{V}$ (Note.4), $R_L = 10 \text{ k}\Omega$, $C_L = 3.3\text{nF}$)

Characteristic	Symbol	Test Condition	Min.	Typ.	Max.	Unit
1. Reference Section						
Output Voltage	Vref	$T_a = 25^\circ\text{C}$, $I_o = 1\text{mA}$	4.90	5.00	5.10	V
Line Regulation	ΔV_{ref}	$12\text{V} \leq V_{CC} \leq 25\text{V}$	-	6	20	mV
Load Regulation	ΔV_{ref}	$1\text{mA} \leq I_o \leq 20\text{mA}$	-	6	25	mV
Temperature Stability	$\Delta V_T / \Delta V_T$	(Note 1)	-	0.2	0.4	mV/ $^\circ\text{C}$
Output Noise Voltage	V_n	$10\text{Hz} \leq f \leq 10\text{kHz}$, $T_a = 25^\circ\text{C}$ (Note 1)	-	50	-	μV
Long Term Stability	S	$T_a = 125^\circ\text{C}$, 1000Hrs (Note 1)	-	5	-	mV
Output Short Circuit	I_{SC}	-	-30	-100	-180	mA
2. Oscillator Section						
Initial Accuracy	f_{SC}	$T_a = 25^\circ\text{C}$	47	52	57	KHz
Voltage Stability	$\Delta f / \Delta V$	$12 \leq V_a \leq 25\text{V}$	-	0.05	1.0	%
Temperature Stability	$\Delta f / \Delta T$	$T_{\text{min}} \leq T_a \leq T_{\text{max}}$ (Note 1)	-	5	-	%
Amplitude	V_4	V_{PIN4} Peak to Peak	-	1.7	-	V
3. Error Amp Section						
Input Voltage	V_2	$V_{\text{PIN1}} = 2.5\text{V}$	2.42	2.50	2.58	V
Input Bias Current	I_b	-	-	-0.3	-2.0	μA
Open Loop Voltage Gain	A_{V01}	$2\text{V} \leq V_o \leq 4\text{V}$	65	90	-	dB
Supply Voltage Rejection	SVR	$12\text{V} \leq V_a \leq 25\text{V}$	60	70	-	dB
Output Sink Current	I_o	$V_{\text{PIN2}} = 2.7\text{V}$, $V_{\text{PIN1}} = 1.1\text{V}$	2	6	-	mA
Output Source Current	I_o	$V_{\text{PIN2}} = 2.3\text{V}$, $V_{\text{PIN1}} = 5\text{V}$	-0.5	-0.8	-	mA
$V_{\text{OUT High}}$	V_{ch}	$V_{\text{PIN2}} = 2.3\text{V}$, $R_L = 15 \text{ k}\Omega$ to Ground	5	6	-	V
$V_{\text{OUT Low}}$	V_{c1}	$V_{\text{PIN2}} = 2.7\text{V}$, $R_L = 15 \text{ k}\Omega$ Pin8	-	0.7	1.1	V
4. Current Sense Section						
Gain	G_V	(Note 2 & 3)	2.8	3.0	3.2	V/V
Maximum Input Signal	V_3	$V_{\text{PIN1}} = 5\text{V}$ (Note 2)	0.9	1.0	1.1	V
Supply Volt Rejection	SVR	$12 \leq V_a \leq 25\text{V}$ (Note 2)	-	70	-	dB
Input Bias Current	I_b	-	-	-2	-10	μA
5. Output Section						
Output Low Level	V_{O1}	$I_{\text{SINK}} = 20\text{mA}$	-	0.1	0.4	V
		$I_{\text{SINK}} = 200\text{mA}$	-	1.5	2.2	V
Output High Level	V_{Oh}	$I_{\text{SOURCE}} = 20\text{mA}$	13.0	13.5	-	V
		$I_{\text{SOURCE}} = 200\text{mA}$	12.0	13.5	-	V
Rise time	t_r	$T_a = 25^\circ\text{C}$, $C_l = 1\text{nF}$ (Note 1)	-	50	150	ns
Fall time	t_f	$T_a = 25^\circ\text{C}$, $C_l = 1\text{nF}$ (Note 1)	-	50	150	ns

Electrical Characteristics(continued)

Characteristic	Symbol	Test Condition	Min.	Typ.	Max.	Unit
6. Under-Voltage Lockout Section						
Start Threshold	V_{th}	V_{PIN7} where $V_{PIN8} \geq 4.9V$	14.5	16.0	17.5	V
Min. Operation Voltage After Turn-On	$V_{CC(min)}$	V_{PIN7} where $V_{PIN8} \leq 1V$	8.5	10.0	11.5	V
7. PWM Section						
Maximum Duty Cycle	DC_{max}	-	93	97	100	ns
8. Total Standby Section						
Start-Up Current	I_{st}	$V_{CC} = 15V$ before turn on	-	0.4	0.7	mA
Operating Supply Current	I_{CC}	$V_{PIN2} = V_{PIN3} = 0V$	-	11	20	mA
Zener Voltage	V_Z	$I_{CC} = 25mA$	-	36	-	V

NOTE: 1.These parameters, although guaranteed,are not 100% tested in production

- 2.Parameter measured at trip piont of latch with $V_{pin2} = 0$
- 3.Gain defined as : $A = \Delta V_{PIN1} / \Delta V_{PIN3}$; $0 \leq V_{PIN3} \leq 0.8V$
- 4.Adjust V_{CC} above the start threshold before setting at 15V

Information in Using IC

1. Under voltage Lockout

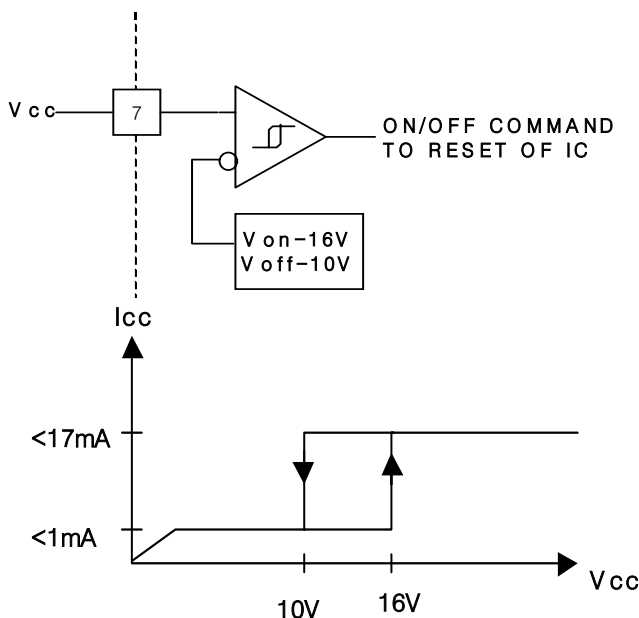

To prevent erratic output behavior which activating the power switch with extraneous leakage currents, during under voltage lockout. Output(pin6) should be shunted to ground with a bleeder resistor.

The Vcc comparator upper and lower threshold are 16V/10V. The large hysteresis and low start up currents makes it ideally suited in off-line converter application where efficient bootstrap start-up techniques are required.

2. Oscillator Waveforms and Maximum Duty Cycle

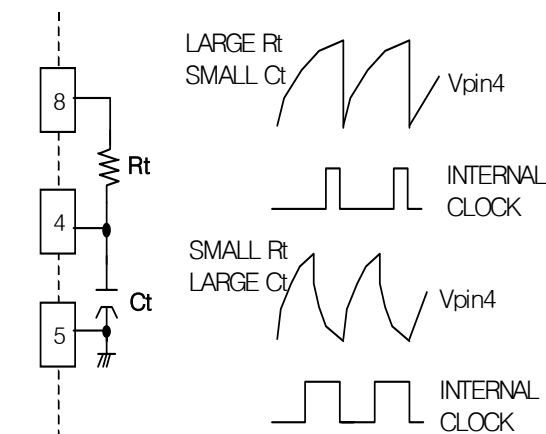

The oscillator frequency is programmed by the values selected for the timing components R_t and C_t . C_t is charged from 5V, V_{ref} , through resistor R_t to approximately 2.8V and discharged to 1.2V by an internal current sink.

During the discharge of C_t , the oscillator generates an internal blanking pulse and the center input NOR gate high. This makes output to be in a low state and control the amount of output dead time.

3. Error AMP Configuration

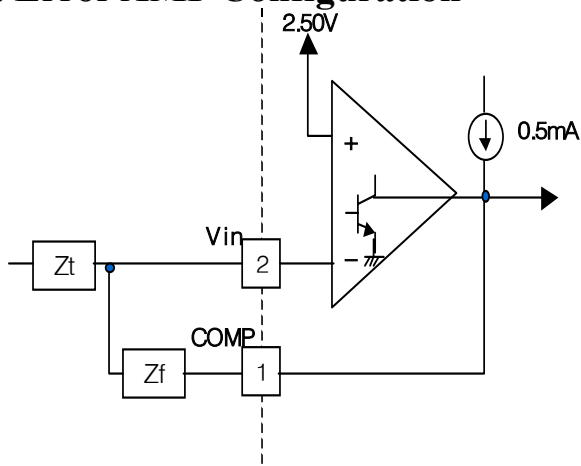

Error amp output (Pin1) is provided for external loop compensation and error amp can source or sink up to 0.5mA. The non-inverting input is internally biased at 2.5V and is not pinned out. The converter output voltage is typically divided down and monitored by the inverting input (pin2).

4. Current Sense Circuit

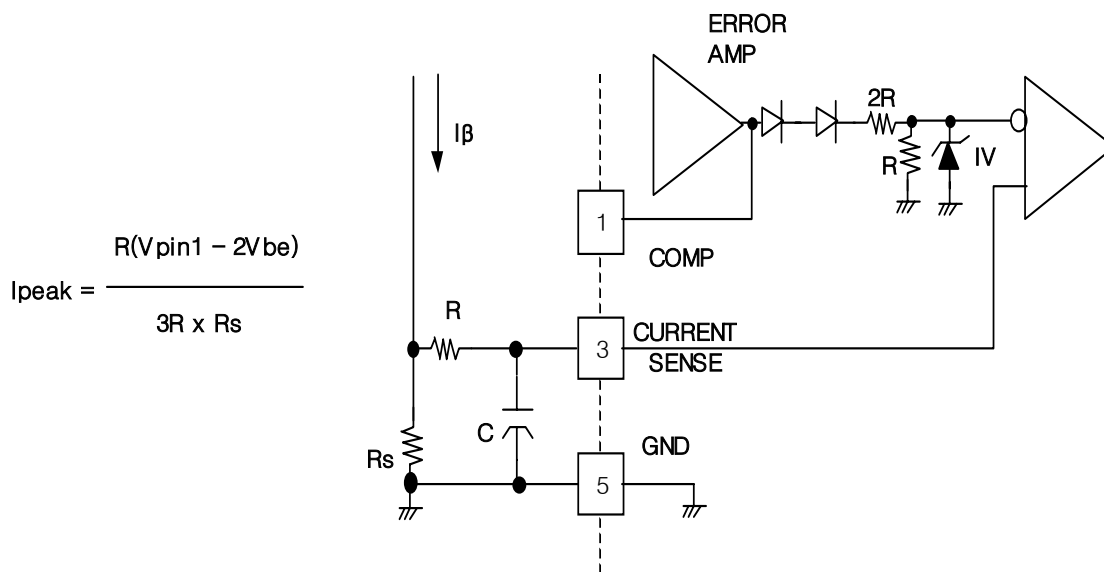

A normal operating conditions occurs when the power supply output is overloaded or its output voltage to 1.0V. Therefore the maximum peak switch current is $I_{pk(max)} = 1.0V/R_s$, and under the normal operating conditions the peak inductor current controlled by the voltage at pin1.

5. Shutdown Techniques

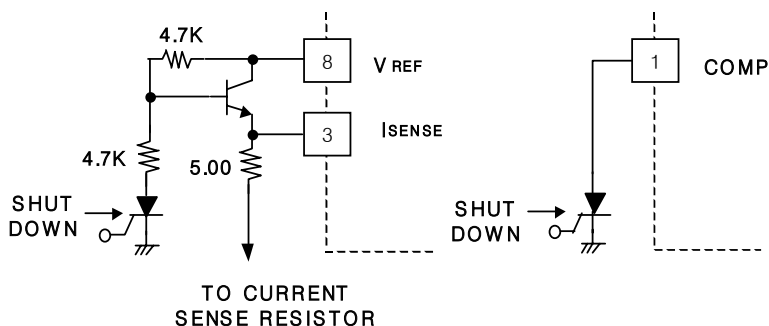

Shutdown of the S3842 can be accomplished by two methods; either raise pin3 above 1V or pull pin1 below a voltage two diodes drops above ground. Either causes the output of the PWM method comparator to be high (refer to

block diagram). The PWM latch is reset dominant so that the output will remain low until the next clock cycle after the shutdown condition at pins 1 and/or 3 is removed. In one example, an externally latched shutdown may be accomplished by adding an SCR which turn off, allowing the SCR to reset.

6. Open Loop Test

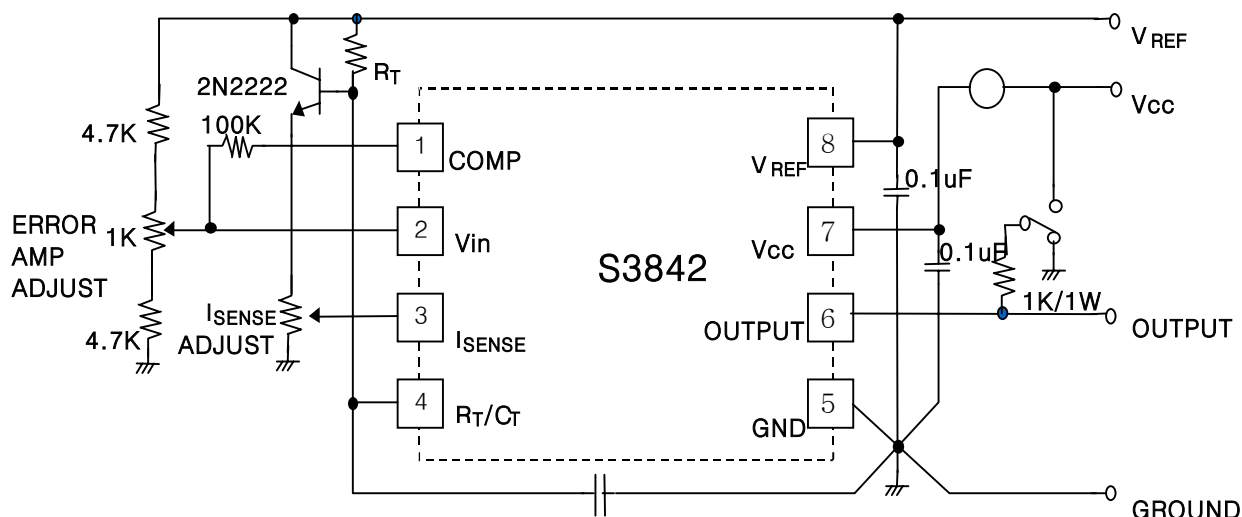

High peak currents associated with capacitive leads necessitate careful grounding techniques. Timing and bypass capacitors should be connected close to Pin5 in a single point ground. The transistor and 5 kΩ potentiometer are used to sample the oscillator waveform and apply an adjustable ramp to Pin3.

7. Slope Compensation

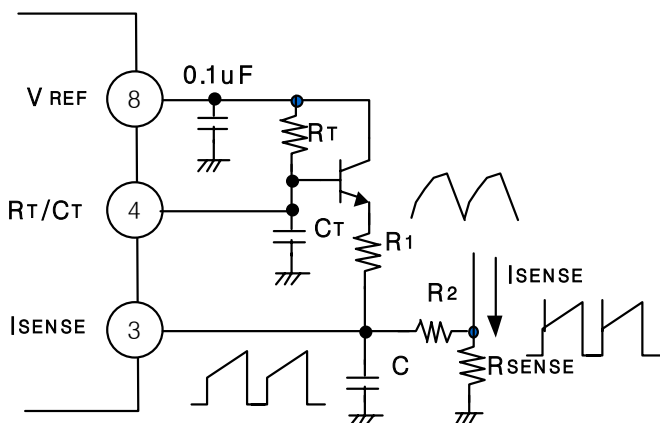

A fraction of the oscillator ramp can be resistively summed with the current sense signal to provide slope compensation for converters requiring duty cycle over 50%. Note that capacitor C, forms a filter with R₂ to suppress the leading edge switch spikes.

Electrical Characteristic Curves

OUTPUT DEAD-TIME vs. OSCILLATOR FREQUENCY

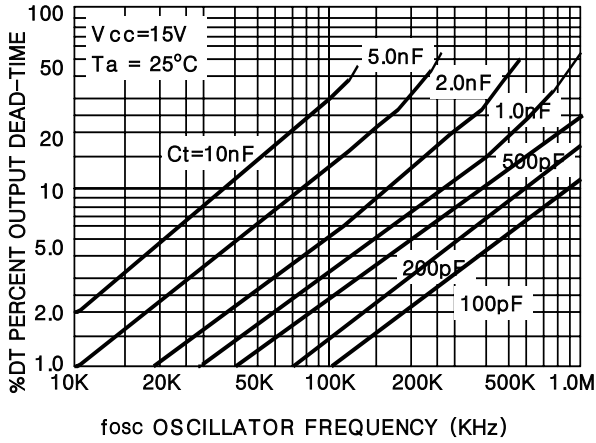

TIMING RESISTOR vs. OSCILLATOR FREQUENCY

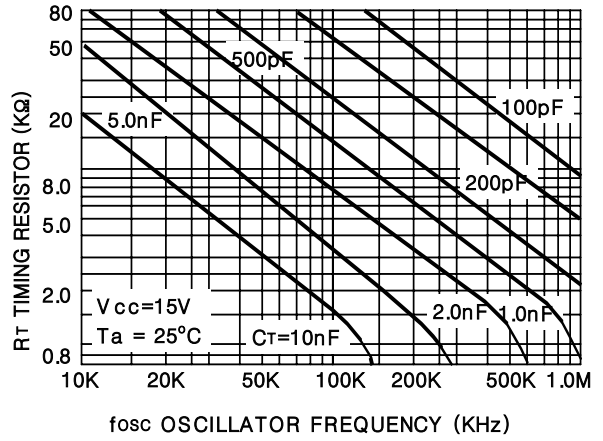

Error Amplifier Open-Loop Frequency Response

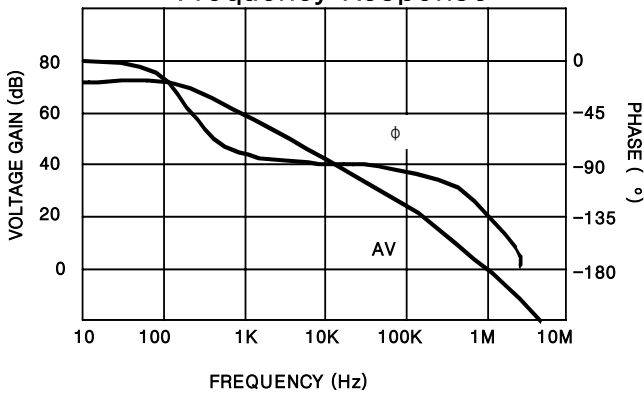

Output Saturation Characteristics

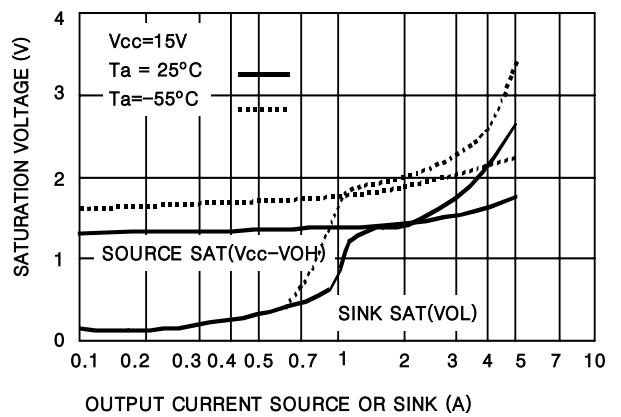

These AUK products are intended for usage in general electronic equipments(Office and communication equipment, measuring equipment, domestic electrification, etc.).

Please make sure that you consult with us before you use these AUK products in equipments which require high quality and/or reliability, and in equipments which could have major impact to the welfare of human life(atomic energy control, airplane, spaceship, traffic signal, combustion central, all types of safety device, etc.).

AUK cannot accept liability to any damage which may occur in case these AUK products were used in the mentioned equipments without prior consultation with AUK.