

Description

- The S71xx prevents the error of system from supply voltage below normal voltage level at the time the power on and instantaneous power off in systems.

Features

- Super low current consumption
- High current of output transistor
- Hysteresis Voltage is Provided

Applications

- As Control Circuit of Battery-Backed Memory
- As Measure Against Erroneous Operations at Power On-Off
- As Resetting Function for the CPU-Mounted Equipment --- PC, Printer, VTR, Fax, C-TV etc.
- As Measure Against System Runaway at Instantaneous Break of Power Supply etc.

Ordering Information

Type NO.	Marking	Package Code
S71xxSF	7□□	SOT-23F

□□: Detecting Voltage Code

Outline Dimensions

Unit : mm

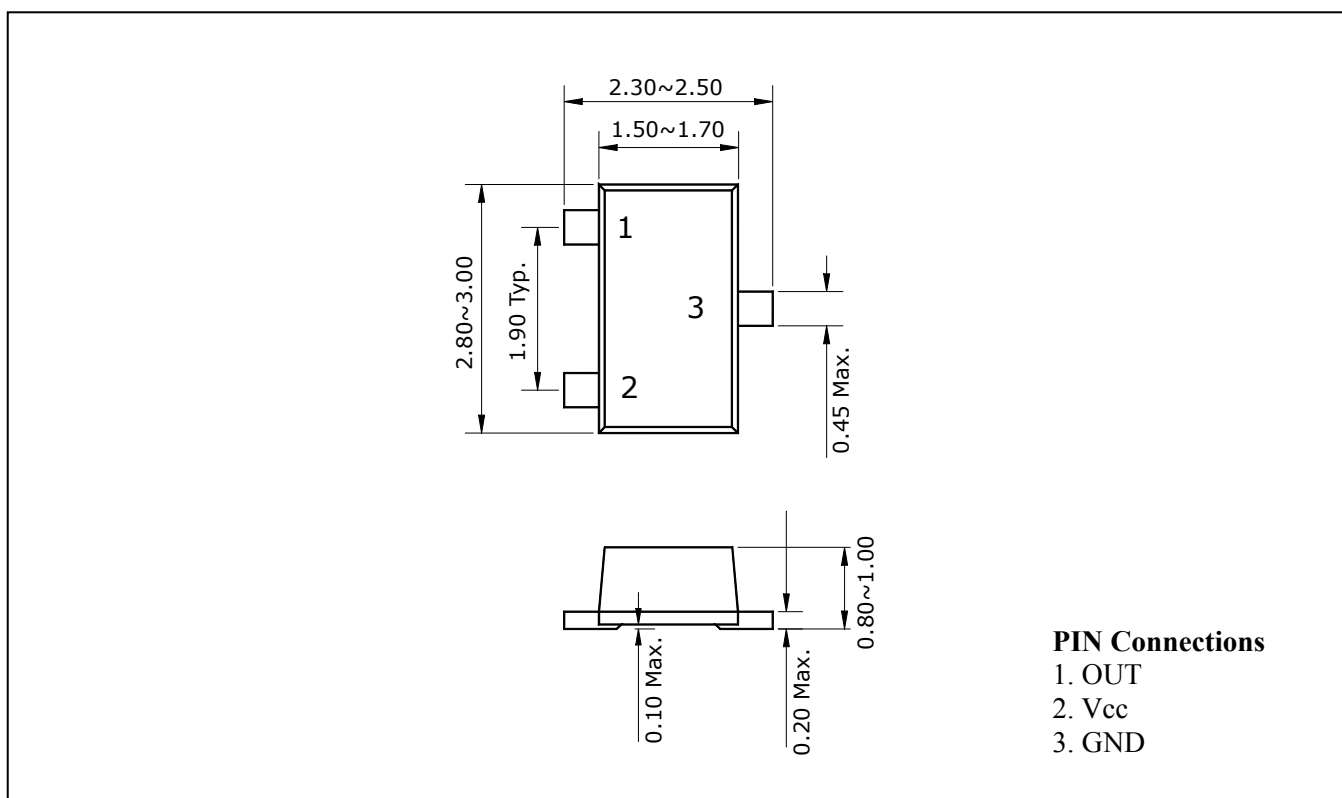

Equivalent Circuit Diagram

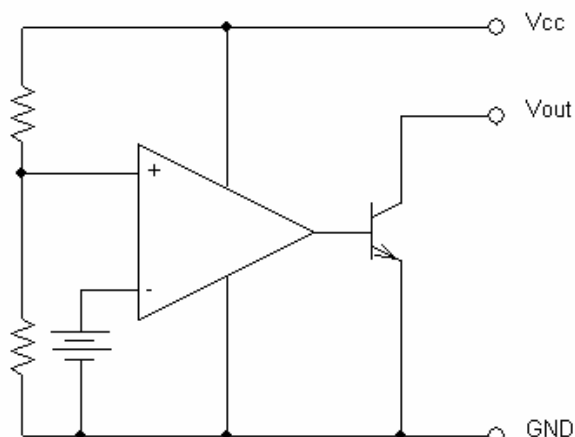

Maximum ratings

(Ta=25°C)

Characteristic	Symbol	Ratings	Unit
Supply Voltage	V_{CC}	-0.3 ~ +10	V
Power Dissipation	P_D^*	300	mW
Output Voltage	V_{OUT}	-0.3 ~ +10	V
Operating Temperature Range	T_{OPR}	-30 ~ +75	°C
Storage Temperature Range	T_{STG}	-55 ~ +150	°C

* With PCB(8×8 mmCopper Area) at Glass Epoxy Board (t=1.7 mm, Area; 20×20 mm)

Electrical Characteristics

(V_{CC}=5V, Ta=25°C)

Characteristic	Symbol	Test Circuit	Test Condition	Min.	Typ.	Max.	Unit
Detecting Voltage	V_S	1	* See Table 1				
Hysteresis Voltage	ΔV_S	1	$R_L=200\Omega$, $V_{CC}=L\rightarrow H\rightarrow L$	-	-	0.4	V
Temperature Coefficient of Detecting Voltage	$V_S/\Delta T$	1	$R_L=200\Omega$, $T_a=-30\sim 75^\circ\text{C}$	-	± 0.01	-	%/°C
Low Level Output voltage	V_{OL}	1	$R_L=200\Omega$, $V_{CC}=V_S$ Min	-	0.1	0.4	V
Leakage Current When OFF	I_{LEAK}	1	$V_{CC}=10V$, $R_L=200\Omega$	-	-	0.1	μA
Circuit current at ON	I_{CCL}	1	$V_{CC}=V_S$ Min	-	-	500	μA
Circuit current at OFF	I_{CCH}	1	$V_{CC}=V_S$ Max +0.1V	-	-	50	μA
Operating Voltage	V_{OPR}	1	$R_L=200\Omega$, $V_{OL}\leq 0.4V$	-	0.8	1.6	V
Output Current at ON I	$I_{OL I}$	1	$R_L=0\Omega$, $V_{CC}=V_S$ Min	10	20	-	mA
Output Current at ON II	$I_{OL II}$	1	$R_L=0\Omega$, $V_{CC}=V_S$ Min, $T_a=-30\sim 75^\circ\text{C}$	8	-	-	mA
L→H Transmission delay time	t_{PLH}	2	$R_L=1.0\text{ k}\Omega$, $C_L=100\text{ pF}$	-	15	-	μs
H→L Transmission delay time	t_{PHL}	2	$R_L=1.0\text{ k}\Omega$, $C_L=100\text{ pF}$	-	10	-	μs

V_S : Standard Detection Voltage

* Table 1

Electrical Characteristics

(V_{CC}=5V, Ta=25°C)

Characteristic	Symbol	Test Circuit	Test Condition	Min.	Typ.	Max.	Unit	
Detecting voltage	V _s	1	R _L =200Ω V _{CC} =H→L V _{OL} ≤0.4V	S7145SF	4.35	4.5	4.65	V
				S7142SF	4.05	4.2	4.35	
				S7139SF	3.75	3.9	4.05	
				S7136SF	3.45	3.6	3.75	
				S7133SF	3.15	3.3	3.45	
				S7131SF	2.95	3.1	3.25	
				S7129SF	2.75	2.9	3.05	
				S7127SF	2.55	2.7	2.85	
				S7125SF	2.35	2.5	2.65	
				S7123SF	2.15	2.3	2.45	
				S7121SF	1.95	2.1	2.25	

Test Circuit 1

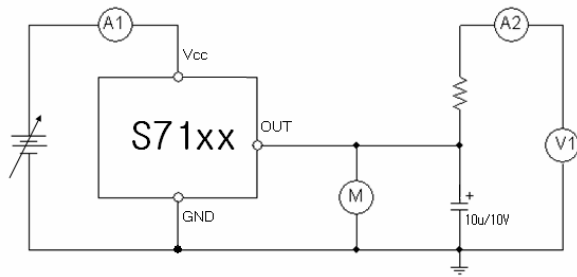

Test Circuit 2

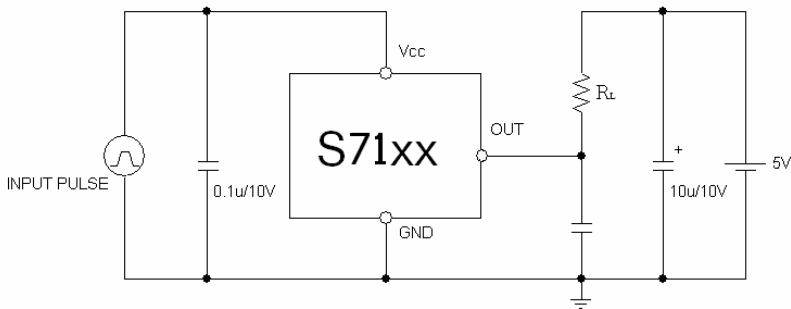

Application Circuit

(1) Battery Low Indicator

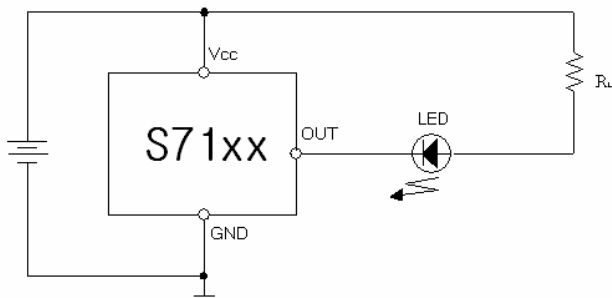

Note 1. : Connecting of LED and R2 obtains a voltage drop indicator.

(2) Resetting for CPU

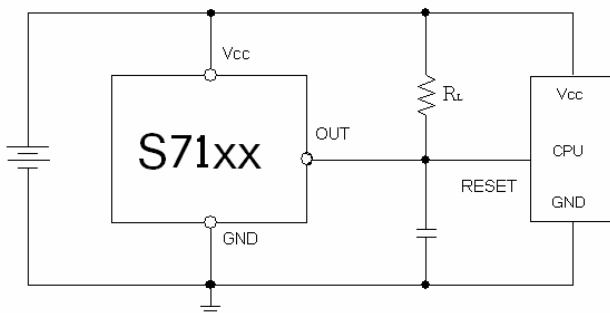

Electrical Characteristic Curves

Fig. 1 $V_O - V_{CC}$

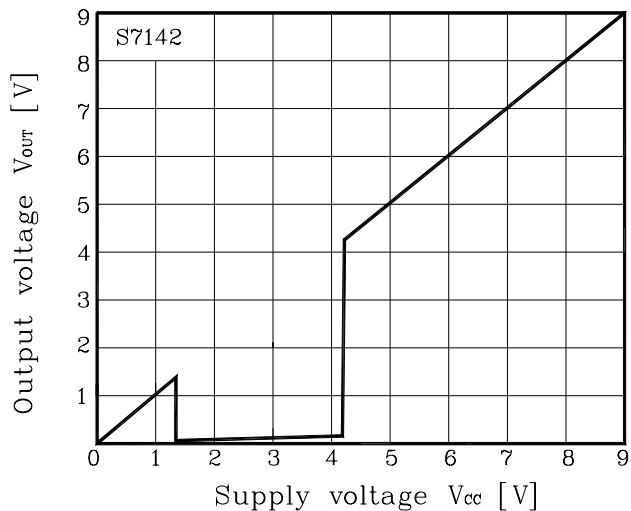

Fig. 2 $\Delta V_S - T_a$

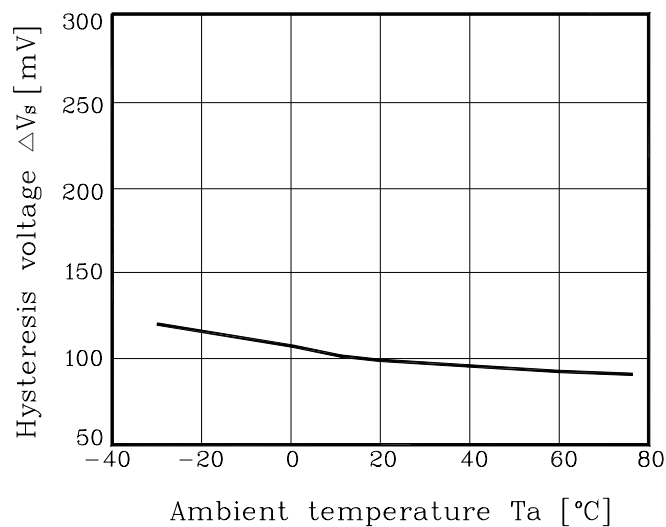

Fig. 3 $V_S - T_a$

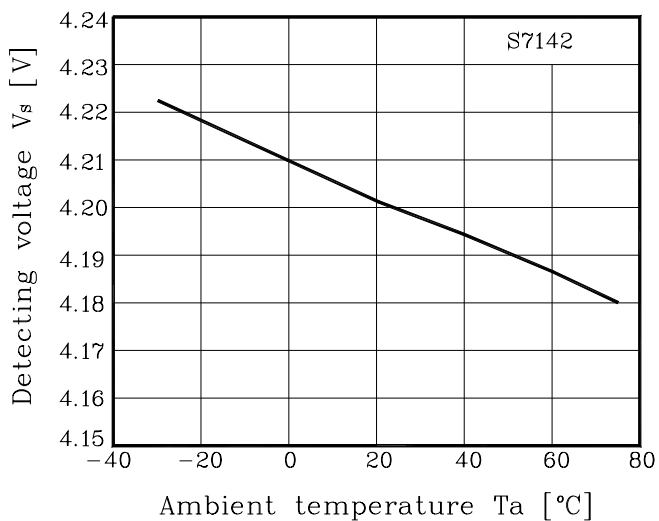

Fig. 4 $V_{OL} - T_a$

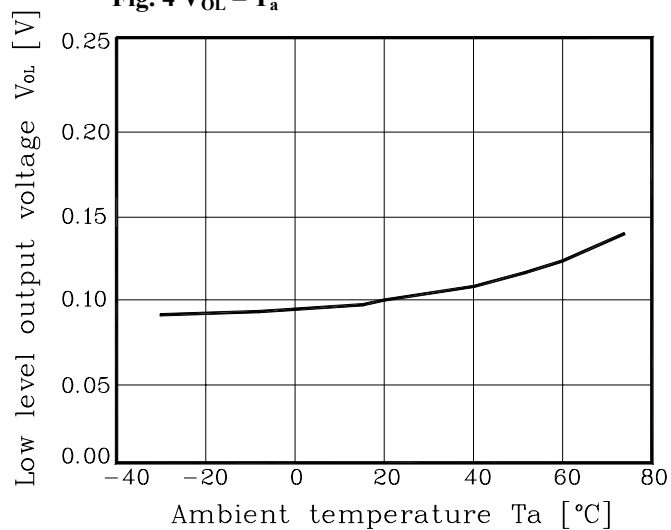
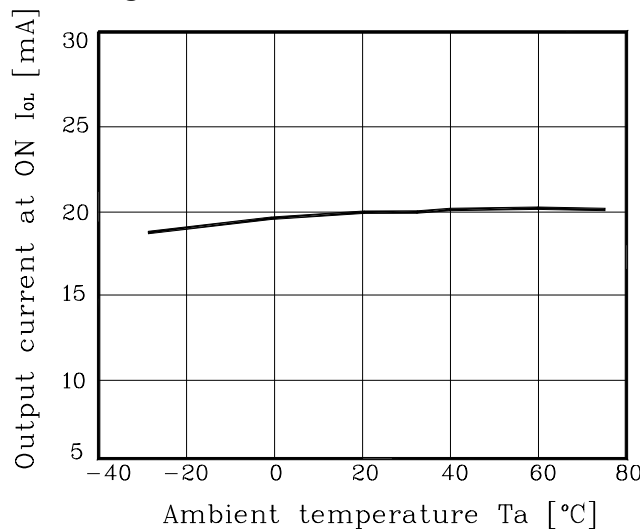

Fig. 5 $I_{OL} - T_a$



The AUK Corp. products are intended for the use as components in general electronic equipment (Office and communication equipment, measuring equipment, home appliance, etc.).

Please make sure that you consult with us before you use these AUK Corp. products in equipments which require high quality and / or reliability, and in equipments which could have major impact to the welfare of human life(atomic energy control, airplane, spaceship, transportation, combustion control, all types of safety device, etc.). AUK Corp. cannot accept liability to any damage which may occur in case these AUK Corp. products were used in the mentioned equipments without prior consultation with AUK Corp..

Specifications mentioned in this publication are subject to change without notice.