

### Description

The SL432 series are 3-terminal precision shunt regulators that are programmable over a wide voltage range of 1.24V to 16V with  $\pm 0.5\%$ ,  $\pm 1.0\%$ ,  $\pm 2.0\%$  tolerance. The SL432 series have a low dynamic impedance of  $0.25\ \Omega$ . These features make the SL432 series an excellent replacement for zener diodes in numerous applications circuits that require a precision reference voltage.

### Features

- Programmable output voltage from 1.24V to 16V
- Voltage reference tolerance :  $\pm 0.5\%$ ,  $\pm 1.0\%$ ,  $\pm 2.0\%$
- Cathode current capability of  $80\ \mu\text{A}$  to  $30\ \text{mA}$

### Ordering Information

Type NO.	Marking	Package Code
SL432xM	SL432□	TO-92M

□: Grade => None: $\pm 2\%$  , A: $\pm 1\%$  , B: $\pm 0.5\%$

### Outline Dimensions ( Unit : mm )

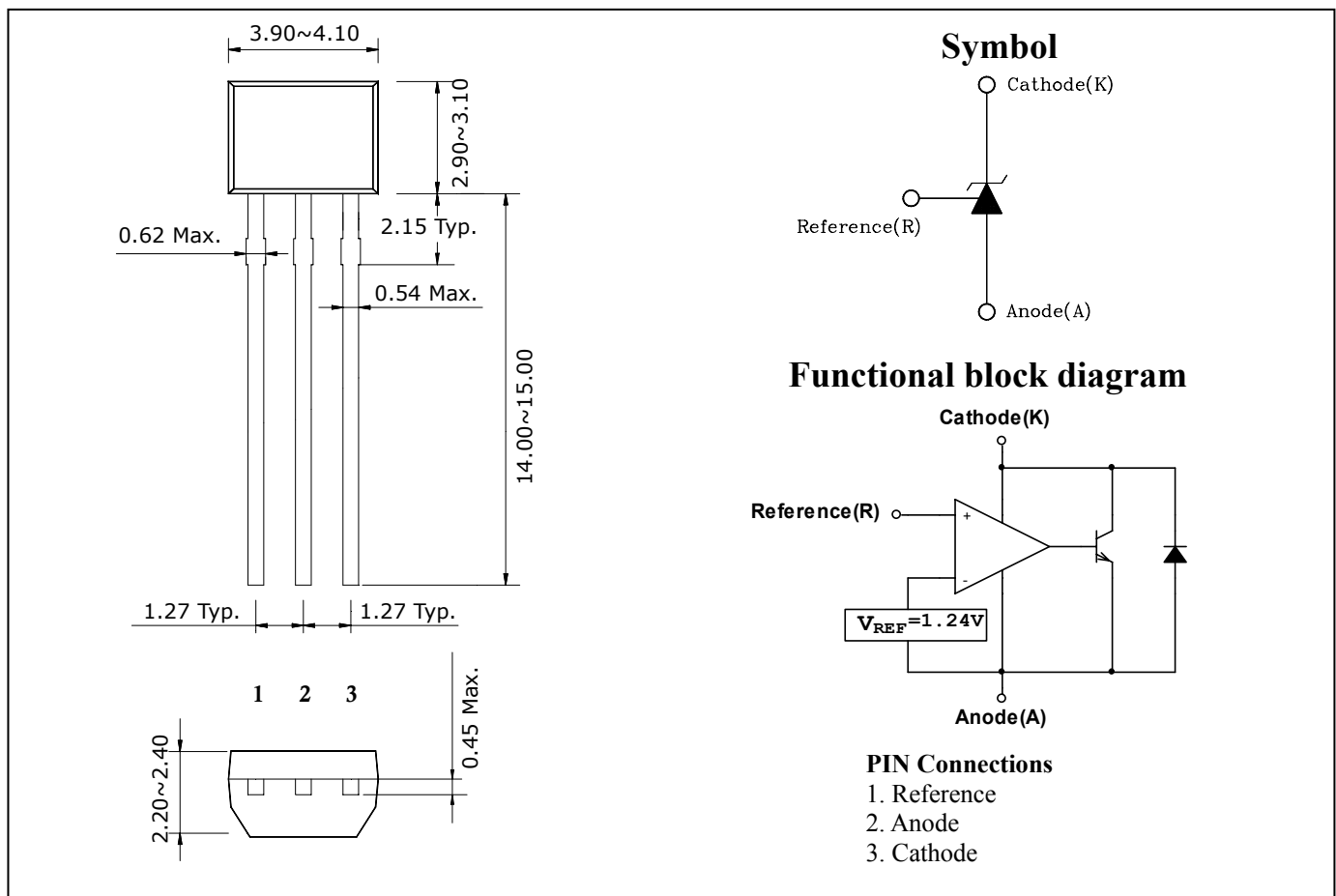

#### Symbol

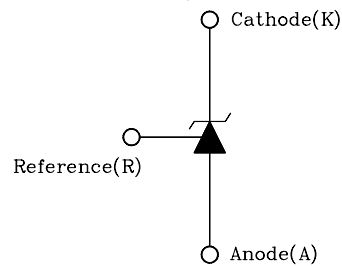

#### Functional block diagram

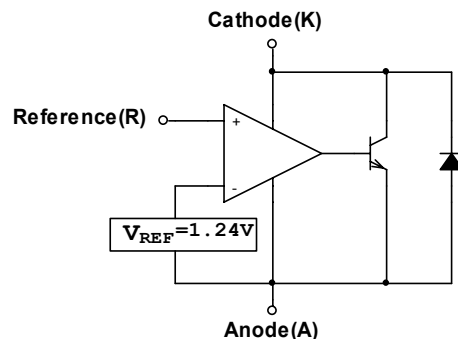

#### PIN Connections

1. Reference
2. Anode
3. Cathode

## Absolute maximum ratings

[Ta=25°C]

Characteristic	Symbol	Rating	Unit
Cathode to Anode voltage	$V_{KA}$	18	V
Cathode current	$I_K$	30	mA
Reference input current	$I_{ref}$	3	mA
Power Dissipation	$P_D$	400	mW
Junction Temperature	$T_J$	150	°C
Operating temperature range	$T_{opr}$	-40 ~ +85	°C
Storage temperature range	$T_{stg}$	-55 ~ +150	°C

## Recommended operating conditions

Characteristic	Symbol	Rating		Unit
		Min.	Max.	
Cathode to Anode voltage	$V_{KA}$	$V_{ref}$	16	V
Cathode current	$I_K$	0.1	30	mA

## Electrical Characteristics (Ta=25°C, unless otherwise noted.)

Characteristic	Symbol	Condition	Min.	Typ.	Max.	Unit	
Reference voltage (Fig.1)	$V_{ref}$	$V_{KA}=V_{ref}, I_K=10mA$	SL432BM	1.234	1.240	1.246	V
			SL432AM	1.228		1.252	
			SL432M	1.215		1.265	
Reference input voltage deviation over temperature (Fig.1, Note1,2)	$\Delta V_{ref}$	$V_{KA}=V_{ref}, I_K=10mA$ @ -40°C ≤ Ta ≤ 85°C	-	10	20	mV	
Ratio of delta reference input voltage to delta cathode voltage (Fig.2)	$\frac{\Delta V_{ref}}{\Delta V_{KA}}$	$I_K=10mA$ $V_{ref} \leq V_{KA} \leq 16V$	-	-1.0	-2.7	mV/V	
		$\Delta V_{ref}=V_{ref}-V_{ref(16V)}$					
		$\Delta V_{KA}=V_{KA(16V)}-V_{ref}$					
Reference current (Fig.2)	$I_{ref}$	$I_K=10mA$ $R1=10K\Omega, R2=\infty$	-	0.15	0.3	μA	
Reference input current deviation over temperature (Fig.2, Note 1,2)	$\Delta I_{ref}$	$I_K=10mA$ $R1=10K\Omega, R2=\infty$ @ -40°C ≤ Ta ≤ 85°C	-	0.04	0.08	μA	
Minimum cathode current for regulation	$I_{K(MIN)}$	$V_{KA}=V_{ref}$	-	55	80	μA	
Off-state cathode current (Fig.3)	$I_{K(off)}$	$V_{KA}=16V, V_{ref}=0V$	-	5	50	nA	
Dynamic impedance (Fig.1, Note3)	$Z_{KA}$	$V_{KA}=V_{ref}, f \leq 1.0KHz$ $0.1mA \leq I_K \leq 30mA$	-	0.25	0.4	Ω	

Fig. 1 Test circuit for  $V_{KA}=V_{ref}$

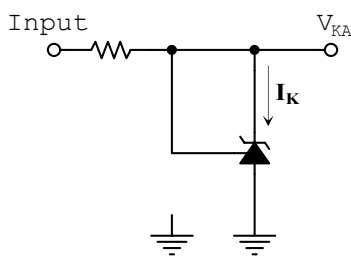

Fig. 2 Test circuit for  $V_{KA}>V_{ref}$

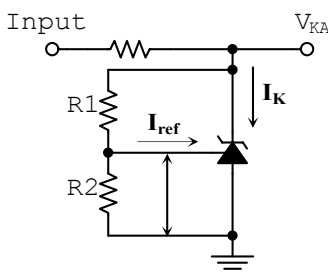
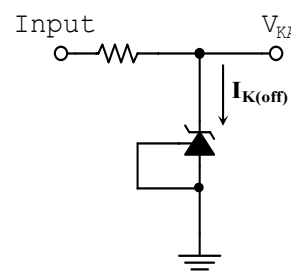

Fig. 3 Test circuit for  $I_{K(off)}$



$$V_{KA} = V_{ref} \times \left(1 + \frac{R_1}{R_2}\right) + I_{ref} \times R_1$$

Note.

1. Ambient temperature range:  $T_{LOW} = -40^{\circ}C$ ,  $T_{High} = 85^{\circ}C$
2. The deviation parameters  $\Delta V_{ref}$  and  $\Delta I_{ref}$  are defined as the difference between the maximum value and minimum value obtained over the full operating ambient temperature range that applied.

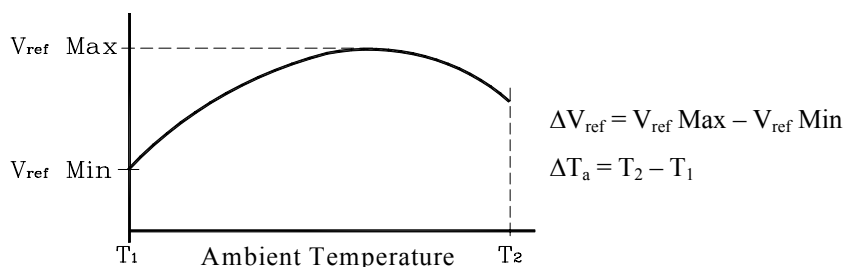

The average temperature coefficient of the reference input voltage,  $\alpha V_{ref}$  is defined as:

$$\alpha V_{ref} \left(\frac{\text{ppm}}{^{\circ}C}\right) = \frac{\left(\frac{\Delta V_{ref}}{V_{ref}(T_a = 25^{\circ}C)} \times 10^6\right)}{\Delta T_a}$$

$\alpha V_{ref}$  can be positive or negative depending on whether  $V_{ref} \text{ Min}$  or  $V_{ref} \text{ Max}$  occurs at the lower ambient temperature, refer to Fig. 8

Example :  $\Delta V_{ref} = 10\text{mV}$  and the slope is positive,

$$\Delta V_{ref} @ 25^{\circ}C = 1.24V$$

$$\Delta T_a = 125^{\circ}C$$

$$\alpha V_{ref} \left(\frac{\text{ppm}}{^{\circ}C}\right) = \frac{\left(\frac{0.010}{1.241}\right) \times 10^6}{125} = 65\text{ppm}/^{\circ}C$$

3. The dynamic impedance  $Z_{KA}$  is defined as:

$$|Z_{KA}| = \frac{\Delta V_{KA}}{\Delta I_K}$$

When the device is operating with two external resistors, R1 and R2, (refer to Fig.2) the total dynamic impedance of the circuit is given by:

$$|Z_{KA}'| = |Z_{KA}| \times \left(1 + \frac{R_1}{R_2}\right)$$

Electrical Characteristics Curves (Continue)

Fig.4  $I_K$  vs  $V_{KA}$  (1)

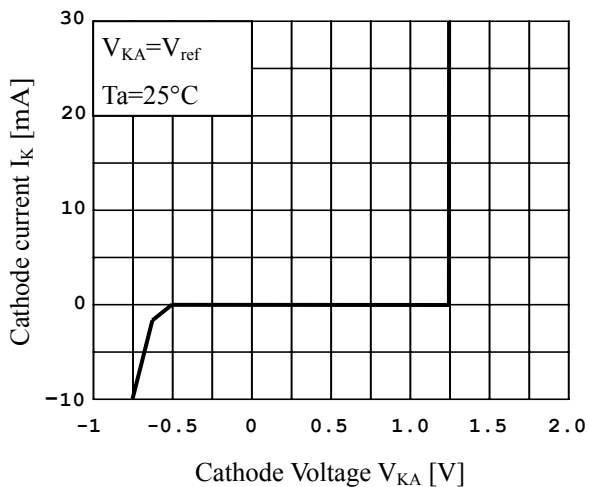

Fig.5  $I_K$  vs  $V_{KA}$  (2)

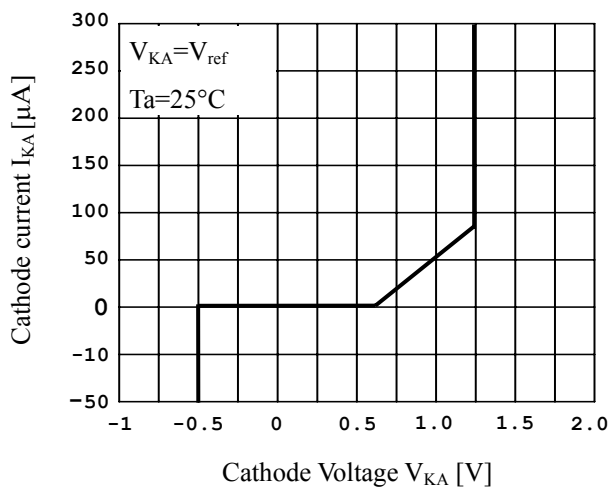

Fig.6  $I_{K(off)}$  vs  $V_{KA}$

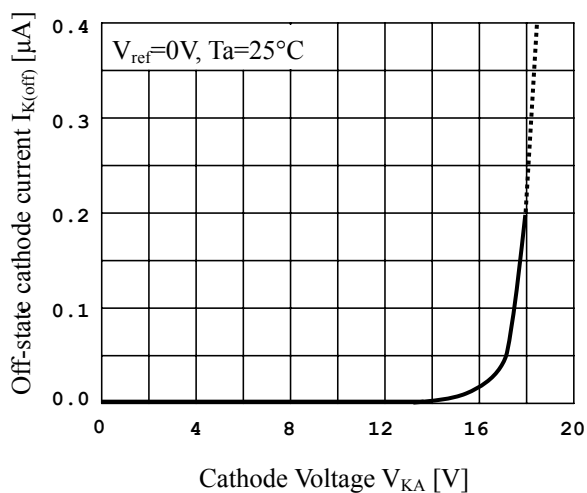

Fig.7  $\Delta V_{ref} / \Delta V_{KA}$  vs  $T_a$

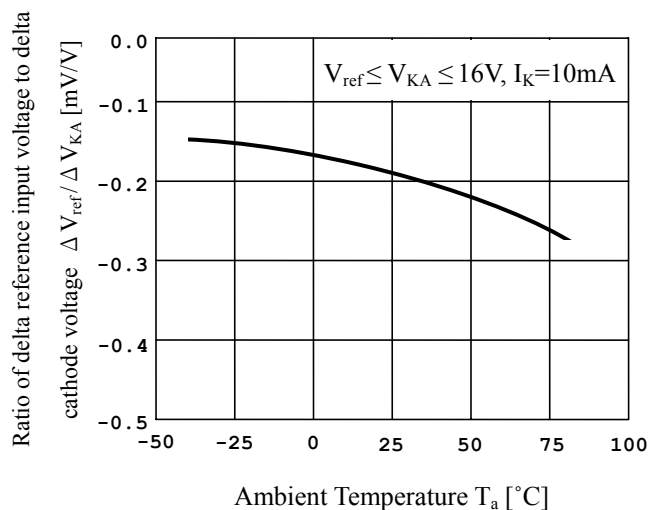

Fig.8  $V_{ref}$  vs  $T_a$

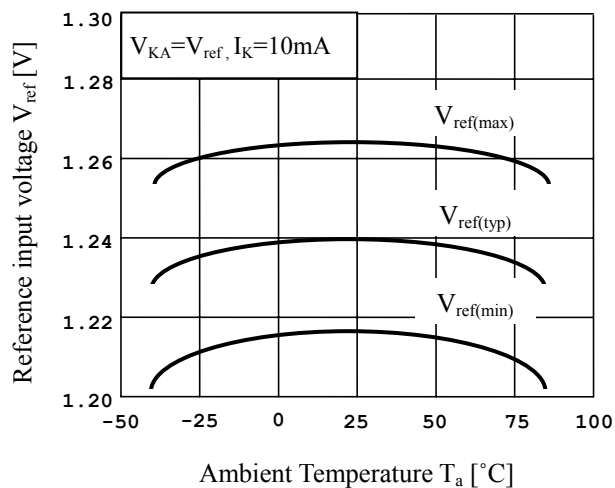
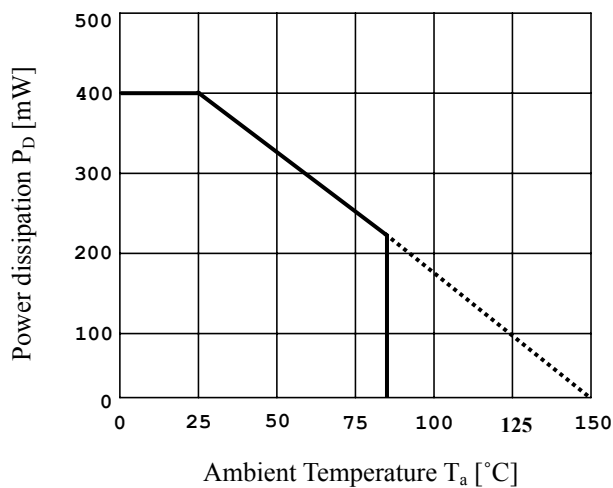
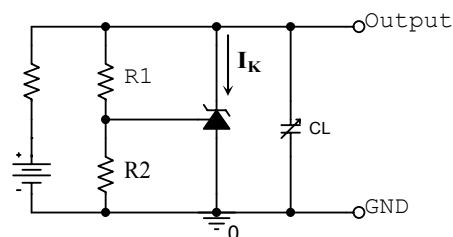
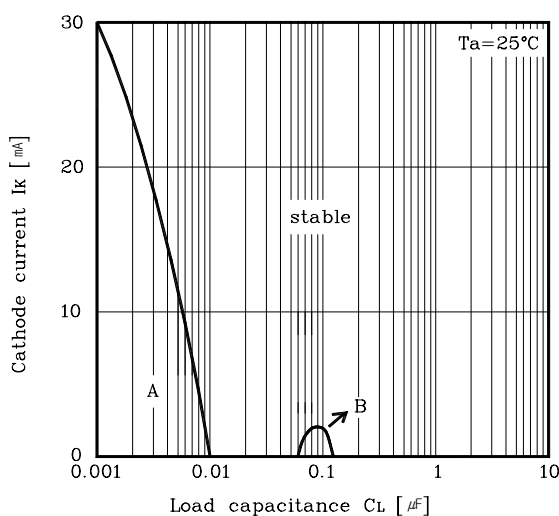

Fig.9  $P_D$  vs  $T_a$



## Electrical Characteristics Curves

Fig.10 Stability Boundary Conditions



Unstable Regions	$V_{KA}$	$R_1$ [K $\Omega$ ]	$R_2$ [K $\Omega$ ]
A, B	$V_{ref}$	0	$\infty$
A	10V	10	1.415

Fig.11 Test circuit for Fig. 10

The AUK Corp. products are intended for the use as components in general electronic equipment (Office and communication equipment, measuring equipment, home appliance, etc.).

Please make sure that you consult with us before you use these AUK Corp. products in equipments which require high quality and / or reliability, and in equipments which could have major impact to the welfare of human life(atomic energy control, airplane, spaceship, transportation, combustion control, all types of safety device, etc.). AUK Corp. cannot accept liability to any damage which may occur in case these AUK Corp. products were used in the mentioned equipments without prior consultation with AUK Corp..

Specifications mentioned in this publication are subject to change without notice.