

Descriptions

This series of fixed-voltage monolithic integrated-circuit voltage regulators is designed for a wide range of applications. These applications include on-card regulation for elimination of Noise and distribution problems associated with single-point regulation. In addition, they can be used with power-pass elements to make high-current voltage regulators. Each of these regulators can deliver up to 100mA of output current. The internal limiting and thermal shutdown features of these regulators make them essentially immune to overload. When used as a replacement for a Zener diode-resistor combination, an effective improvement in output impedance can be obtained together with lower-bias current.

Features

- 3-Terminal Regulators
- Output Current of 100 mA
- Thermal Shutdown Protection
- Short-Circuit Limit Protection

Ordering Information

Type NO.	Marking	Package Code
S78Lxx	S78L□□	TO-92
□□: Voltage Code (05:5V, 06:6V, 08:8V, 09:9V, 10:10V, 12:12V, 15:15V, 18:18V, 24:24V)		

Outline Dimensions (Unit : mm)

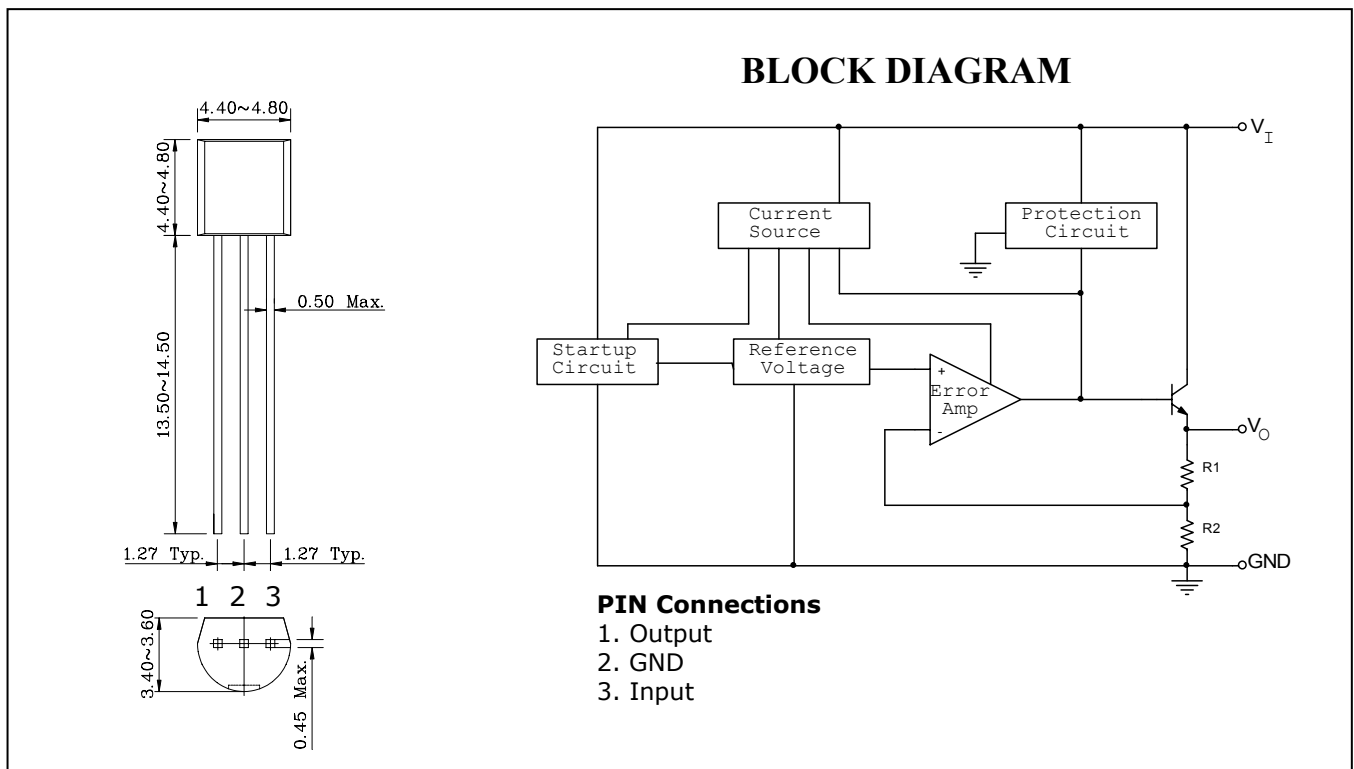

Absolute maximum ratings

[Ta=25°C]

Characteristics	Symbol	Rating		Unit
Input Voltage	V _I	S78L05 Thru S78L10	30	V
		S78L12 Thru S78L18	35	
		S78L24	40	
Power Dissipation	P _D	625		mW
Junction Temperature	T _J	150		°C
Operating temperature range	T _{opr}	-30 ~ +75		°C
Storage temperature range	T _{stg}	-55 ~ +150		°C

Device Selection Guide

Device	Output Voltage
S78L05	5.0V
S78L06	6.0V
S78L08	8.0V
S78L09	9.0V
S78L10	10V
S78L12	12V
S78L15	15V
S78L18	18V
S78L24	24V

Electrical Characteristics

(Electrical Characteristics at $V_I=10V$, $I_O=40mA$, $C_I=0.33\mu F$, $C_O=0.1\mu F$, $0^\circ C \leq T_J \leq 125^\circ C$, Unless otherwise specified)

Parameter	Symbol	Test Condition*		S78L05			Unit
				Min.	Typ.	Max.	
Output Voltage**	V_O	-	$T_J=25^\circ C$	4.8	5	5.2	V
		$I_O=1mA \sim 40mA$ $V_I=7V \sim 20V$	-	4.75	-	5.25	
		$I_O=1mA \sim 70mA$ $V_I=10V$	-	4.75	-	5.25	
Line Regulation	$\Delta V_{O(\Delta V_I)}$	$V_I=7V \sim 20V$	$T_J=25^\circ C$	-	32	150	mV
		$V_I=8V \sim 20V$		-	26	100	
Load Regulation	$\Delta V_{O(\Delta I_L)}$	$I_O=1mA \sim 100mA$	$T_J=25^\circ C$	-	15	60	mV
		$I_O=1mA \sim 40mA$		-	8	30	
Quiescent Current	I_{QC}	-	$T_J=25^\circ C$	-	3.8	6	mA
			$T_J=125^\circ C$	-	-	5.5	
Quiescent Current Change	ΔI_{QC}	$V_I=8V \sim 20V$	-	-	-	1.5	mA
		$I_O=1mA \sim 40mA$		-	-	0.1	
Dropout Voltage	V_{DROP}	-	$T_J=25^\circ C$	-	1.7	-	V
Ripple Rejection	RR	$V_I=8V \sim 18V$, $f=120Hz$	-	41	49	-	dB

Electrical Characteristics

(Electrical Characteristics at $V_I=11V$, $I_O=40mA$, $C_I=0.33\mu F$, $C_O=0.1\mu F$, $0^\circ C \leq T_J \leq 125^\circ C$, Unless otherwise specified)

Parameter	Symbol	Test Condition*		S78L06			Unit
				Min.	Typ.	Max.	
Output Voltage**	V_O	-	$T_J=25^\circ C$	5.75	6	6.25	V
		$I_O=1mA \sim 40mA$ $V_I=8V \sim 20V$	-	5.7	-	6.3	
		$I_O=1mA \sim 70mA$ $V_I=11V$	-	5.7	-	6.3	
Line Regulation	$\Delta V_{O(\Delta V_I)}$	$V_I=8V \sim 20V$	$T_J=25^\circ C$	-	35	175	mV
		$V_I=9V \sim 20V$		-	29	125	
Load Regulation	$\Delta V_{O(\Delta I_L)}$	$I_O=1mA \sim 100mA$	$T_J=25^\circ C$	-	16	80	mV
		$I_O=1mA \sim 40mA$		-	9	40	
Quiescent Current	I_{QC}	-	$T_J=25^\circ C$	-	3.9	6	mA
			$T_J=125^\circ C$	-	-	5.5	
Quiescent Current Change	ΔI_{QC}	$V_I=9V \sim 20V$	-	-	-	1.5	mA
		$I_O=1mA \sim 40mA$		-	-	0.1	
Dropout Voltage	V_{DROP}	-	$T_J=25^\circ C$	-	1.7	-	V
Ripple Rejection	RR	$V_I=9V \sim 19V$, $f=120Hz$	-	40	48	-	dB

Electrical Characteristics

(Electrical Characteristics at $V_I=14V$, $I_O=40mA$, $C_I=0.33\mu F$, $C_O=0.1\mu F$, $0^\circ C \leq T_J \leq 125^\circ C$, Unless otherwise specified)

Parameter	Symbol	Test Condition*		S78L08			Unit
				Min.	Typ.	Max.	
Output Voltage**	V_O	-	$T_J=25^\circ C$	7.7	8	8.3	V
		$I_O=1mA \sim 40mA$ $V_I=10.5V \sim 23V$	-	7.6	-	8.4	
		$I_O=1mA \sim 70mA$ $V_I=14V$	-	7.6	-	8.4	
Line Regulation	$\Delta V_{O(\Delta V_I)}$	$V_I=10.5V \sim 23V$	$T_J=25^\circ C$	-	42	175	mV
		$V_I=11V \sim 23V$		-	36	125	
Load Regulation	$\Delta V_{O(\Delta I_L)}$	$I_O=1mA \sim 100mA$	$T_J=25^\circ C$	-	18	80	mV
		$I_O=1mA \sim 40mA$		-	10	40	
Quiescent Current	I_{QC}	-	$T_J=25^\circ C$	-	4	6	mA
			$T_J=125^\circ C$	-	-	5.5	
Quiescent Current Change	ΔI_{QC}	$V_I=11V \sim 23V$	-	-	-	1.5	mA
		$I_O=1mA \sim 40mA$		-	-	0.1	
Dropout Voltage	V_{DROP}	-	$T_J=25^\circ C$	-	1.7	-	V
Ripple Rejection	RR	$V_I=13V \sim 23V$, $f=120Hz$	-	37	46	-	dB

Electrical Characteristics

(Electrical Characteristics at $V_I=16V$, $I_O=40mA$, $C_I=0.33\mu F$, $C_O=0.1\mu F$, $0^\circ C \leq T_J \leq 125^\circ C$, Unless otherwise specified)

Parameter	Symbol	Test Condition*		S78L09			Unit
				Min.	Typ.	Max.	
Output Voltage**	V_O	-	$T_J=25^\circ C$	8.6	9	9.4	V
		$I_O=1mA \sim 40mA$ $V_I=12V \sim 24V$	-	8.55	-	9.45	
		$I_O=1mA \sim 70mA$ $V_I=16V$	-	8.55	-	9.45	
Line Regulation	$\Delta V_{O(\Delta V_I)}$	$V_I=12V \sim 24V$	$T_J=25^\circ C$	-	45	175	mV
		$V_I=13V \sim 24V$		-	40	125	
Load Regulation	$\Delta V_{O(\Delta I_L)}$	$I_O=1mA \sim 100mA$	$T_J=25^\circ C$	-	19	90	mV
		$I_O=1mA \sim 40mA$		-	11	40	
Quiescent Current	I_{QC}	-	$T_J=25^\circ C$	-	4.1	6	mA
			$T_J=125^\circ C$	-	-	5.5	
Quiescent Current Change	ΔI_{QC}	$V_I=13V \sim 24V$	-	-	-	1.5	mA
		$I_O=1mA \sim 40mA$		-	-	0.1	
Dropout Voltage	V_{DROP}	-	$T_J=25^\circ C$	-	1.7	-	V
Ripple Rejection	RR	$V_I=15V \sim 25V$, $f=120Hz$	-	38	45	-	dB

Electrical Characteristics

(Electrical Characteristics at $V_I=17V$, $I_O=40mA$, $C_I=0.33\mu F$, $C_O=0.1\mu F$, $0^\circ C \leq T_J \leq 125^\circ C$, Unless otherwise specified)

Parameter	Symbol	Test Condition*		S78L10			Unit
				Min.	Typ.	Max.	
Output Voltage**	V_O	-	$T_J=25^\circ C$	9.6	10	10.4	V
		$I_O=1mA \sim 40mA$ $V_I=13V \sim 25V$	-	9.5	-	10.5	
		$I_O=1mA \sim 70mA$ $V_I=17V$	-	9.5	-	10.5	
Line Regulation	$\Delta V_{O(\Delta V_I)}$	$V_I=13V \sim 25V$	$T_J=25^\circ C$	-	51	175	mV
		$V_I=14V \sim 25V$		-	42	125	
Load Regulation	$\Delta V_{O(\Delta I_L)}$	$I_O=1mA \sim 100mA$	$T_J=25^\circ C$	-	20	90	mV
		$I_O=1mA \sim 40mA$		-	11	40	
Quiescent Current	I_{QC}	-	$T_J=25^\circ C$	-	4.2	6	mA
			$T_J=125^\circ C$	-	-	5.5	
Quiescent Current Change	ΔI_{QC}	$V_I=14V \sim 25V$	-	-	-	1.5	mA
		$I_O=1mA \sim 40mA$		-	-	0.1	
Dropout Voltage	V_{DROP}	-	$T_J=25^\circ C$	-	1.7	-	V
Ripple Rejection	RR	$V_I=15V \sim 25V$, $f=120Hz$	-	37	44	-	dB

Electrical Characteristics

(Electrical Characteristics at $V_I=19V$, $I_O=40mA$, $C_I=0.33\mu F$, $C_O=0.1\mu F$, $0^\circ C \leq T_J \leq 125^\circ C$, Unless otherwise specified)

Parameter	Symbol	Test Condition*		S78L12			Unit
				Min.	Typ.	Max.	
Output Voltage**	V_O	-	$T_J=25^\circ C$	11.5	12	12.5	V
		$I_O=1mA \sim 40mA$ $V_I=14V \sim 27V$	-	11.4	-	12.5	
		$I_O=1mA \sim 70mA$ $V_I=19V$	-	11.4	-	12.6	
Line Regulation	$\Delta V_{O(\Delta V_I)}$	$V_I=14.5V \sim 27V$	$T_J=25^\circ C$	-	55	250	mV
		$V_I=16V \sim 27V$		-	49	200	
Load Regulation	$\Delta V_{O(\Delta I_L)}$	$I_O=1mA \sim 100mA$	$T_J=25^\circ C$	-	22	100	mV
		$I_O=1mA \sim 40mA$		-	13	50	
Quiescent Current	I_{QC}	-	$T_J=25^\circ C$	-	4.3	6.5	mA
			$T_J=125^\circ C$	-	-	5	
Quiescent Current Change	ΔI_{QC}	$V_I=16V \sim 27V$	-	-	-	1.5	mA
		$I_O=1mA \sim 40mA$		-	-	0.1	
Dropout Voltage	V_{DROP}	-	$T_J=25^\circ C$	-	1.7	-	V
Ripple Rejection	RR	$V_I=15V \sim 25V$, $f=120Hz$	-	37	42	-	dB

Electrical Characteristics

(Electrical Characteristics at $V_I=23V$, $I_O=40mA$, $C_I=0.33\mu F$, $C_O=0.1\mu F$, $0^\circ C \leq T_J \leq 125^\circ C$, Unless otherwise specified)

Parameter	Symbol	Test Condition*		S78L15			Unit
				Min.	Typ.	Max.	
Output Voltage**	V_O	-	$T_J=25^\circ C$	14.4	15	15.6	V
		$I_O=1mA \sim 40mA$ $V_I=17.5V \sim 30V$	-	14.25	-	15.75	
		$I_O=1mA \sim 70mA$ $V_I=23V$	-	14.25	-	15.75	
Line Regulation	$\Delta V_{O(\Delta V_I)}$	$V_I=17.5V \sim 30V$	$T_J=25^\circ C$	-	65	300	mV
		$V_I=19V \sim 30V$		-	58	250	
Load Regulation	$\Delta V_{O(\Delta I_L)}$	$I_O=1mA \sim 100mA$	$T_J=25^\circ C$	-	25	150	mV
		$I_O=1mA \sim 40mA$		-	15	75	
Quiescent Current	I_{QC}	-	$T_J=25^\circ C$	-	4.6	6.5	mA
			$T_J=125^\circ C$	-	-	6	
Quiescent Current Change	ΔI_{QC}	$V_I=19V \sim 30V$	-	-	-	1.5	mA
		$I_O=1mA \sim 40mA$		-	-	0.1	
Dropout Voltage	V_{DROP}	-	$T_J=25^\circ C$	-	1.7	-	V
Ripple Rejection	RR	$V_I=18.5V \sim 28.5V$, $f=120Hz$	-	34	39	-	dB

Electrical Characteristics

(Electrical Characteristics at $V_I=26V$, $I_O=40mA$, $C_I=0.33\mu F$, $C_O=0.1\mu F$, $0^\circ C \leq T_J \leq 125^\circ C$, Unless otherwise specified)

Parameter	Symbol	Test Condition*		S78L18			Unit
				Min.	Typ.	Max.	
Output Voltage**	V_O	-	$T_J=25^\circ C$	17.3	18	18.7	V
		$I_O=1mA \sim 40mA$ $V_I=20.5V \sim 33V$	-	17.1	-	18.9	
		$I_O=1mA \sim 70mA$ $V_I=26V$	-	17.1	-	18.9	
Line Regulation	$\Delta V_{O(\Delta V_I)}$	$V_I=20.5V \sim 33V$	$T_J=25^\circ C$	-	70	360	mV
		$V_I=22V \sim 33V$		-	64	300	
Load Regulation	$\Delta V_{O(\Delta I_L)}$	$I_O=1mA \sim 100mA$	$T_J=25^\circ C$	-	27	180	mV
		$I_O=1mA \sim 40mA$		-	19	90	
Quiescent Current	I_{QC}	-	$T_J=25^\circ C$	-	4.7	6.5	mA
			$T_J=125^\circ C$	-	-	6	
Quiescent Current Change	ΔI_{QC}	$V_I=22V \sim 33V$	-	-	-	1.5	mA
		$I_O=1mA \sim 40mA$		-	-	0.1	
Dropout Voltage	V_{DROP}	-	$T_J=25^\circ C$	-	1.7	-	V
Ripple Rejection	RR	$V_I=21.5V \sim 31.5V$, $f=120Hz$	-	32	36	-	dB

Electrical Characteristics

(Electrical Characteristics at $V_I=32V$, $I_O=40mA$, $C_I=0.33 \mu F$, $C_O=0.1 \mu F$, $0^\circ C \leq T_J \leq 125^\circ C$, Unless otherwise specified)

Parameter	Symbol	Test Condition*		S78L24			Unit
				Min.	Typ.	Max.	
Output Voltage**	V_O	-	$T_J=25^\circ C$	23	24	25	V
		$I_O=1mA \sim 40mA$ $V_I=26.5V \sim 39V$	-	22.8	-	25.2	
		$I_O=1mA \sim 70mA$ $V_I=32V$	-	22.8	-	25.2	
Line Regulation	$\Delta V_{O(\Delta V_I)}$	$V_I=26.5V \sim 39V$	$T_J=25^\circ C$	-	95	480	mV
		$V_I=29V \sim 39V$		-	78	400	
Load Regulation	$\Delta V_{O(\Delta I_L)}$	$I_O=1mA \sim 100mA$	$T_J=25^\circ C$	-	41	240	mV
		$I_O=1mA \sim 40mA$		-	28	120	
Quiescent Current	I_{QC}	-	$T_J=25^\circ C$	-	4.8	6.5	mA
			$T_J=125^\circ C$	-	-	6	
Quiescent Current Change	ΔI_{QC}	$V_I=28V \sim 39V$	-	-	-	1.5	mA
		$I_O=1mA \sim 40mA$		-	-	0.1	
Dropout Voltage	V_{DROP}	-	$T_J=25^\circ C$	-	1.7	-	V
Ripple Rejection	RR	$V_I=27.5V \sim 37.5V$, $f=120Hz$	-	30	33	-	dB

* Pulse testing techniques are used to maintain the junction temperature as close to the ambient temperature as possible.

Thermal effects must be taken into account separately. All characteristics are measured with a $0.33 \mu F$ capacitor across the input and a $0.1 \mu F$ capacitor across the output.

** This specification applies only for dc power dissipation permitted by absolute maximum ratings.

These AUK Corp. products are intended for usage in general electronic equipment (Office and communication equipment, measuring equipment, domestic electrification, etc.) Please make sure that you consult with us before you use these AUK products in equipments which require high quality and/or reliability, and in equipments which could have major impact to the welfare of human life(atomic energy control, airplane, spaceship, traffic signal, combustion central, all types of safety device, etc.) AUK cannot accept liability to any damage which may occur in case these AUK products were used in the mentioned equipments without prior consultation with AUK.