

**Description**

- High speed switching application.
- Analog switch application.

**Features**

- -2.5V Gate drive.
- Low threshold voltage :  $V_{th} = -0.5 \sim -1.5V$ .
- High speed.

**Ordering Information**

Type NO.	Marking	Package Code
STJ828UF	J28	SOT-323F

**Outline Dimensions**

unit : mm

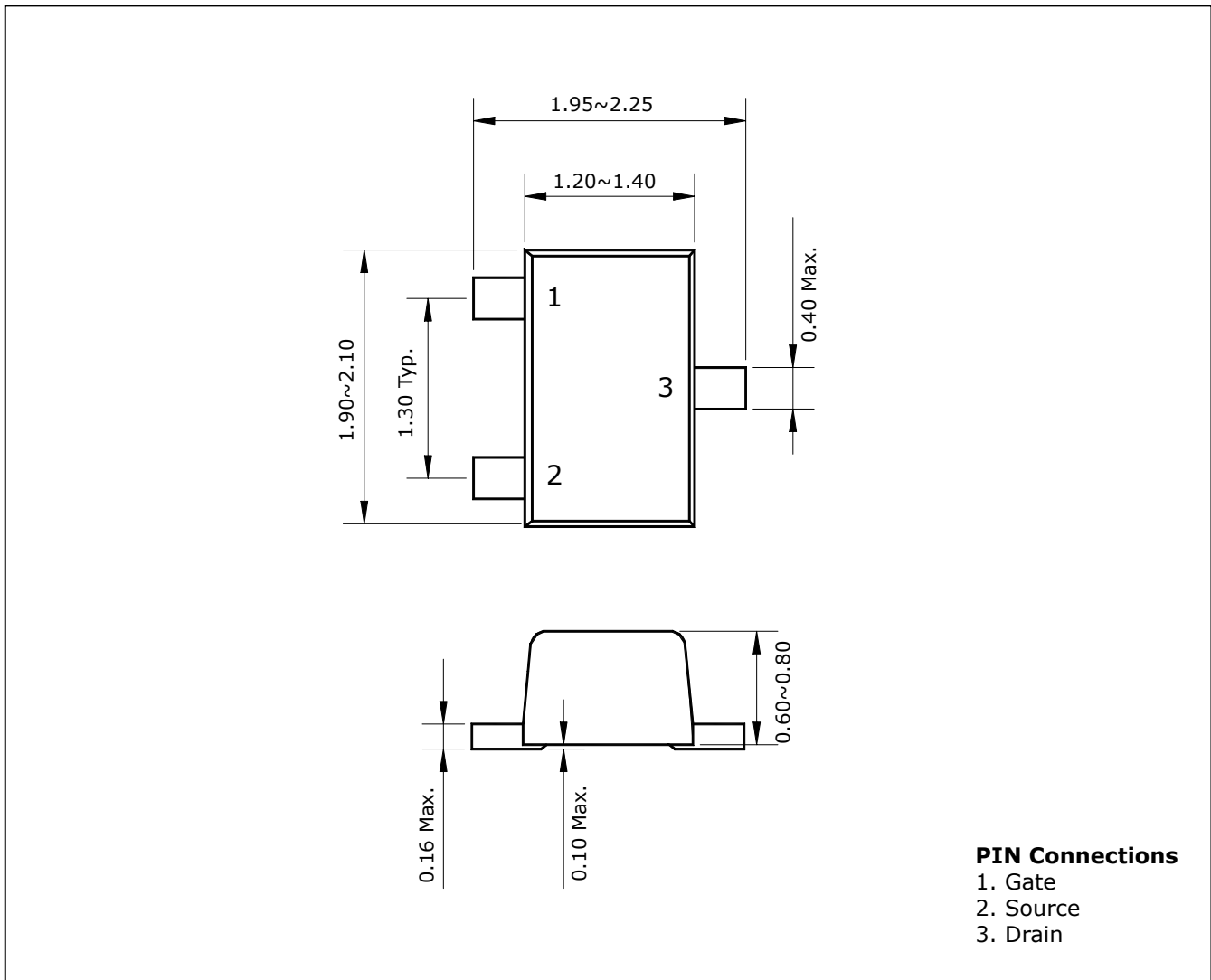

## Absolute maximum ratings

(Ta=25°C)

Characteristic	Symbol	Ratings	Unit
Drain-Source voltage	$V_{DS}$	-20	V
Gate-Source voltage	$V_{GSS}$	$\pm 7$	V
DC Drain current	$I_D$	-50	mA
Drain Power dissipation	$P_D$	150	mW
Channel temperature	$T_{ch}$	150	°C
Storage temperature range	$T_{stg}$	-55~150	°C

## Electrical Characteristics

(Ta=25°C)

Characteristic	Symbol	Test Condition	Min.	Typ.	Max.	Unit
Drain-Source breakdown voltage	$BV_{DSS}$	$I_D = -100\mu A, V_{GS} = 0$	-20			V
Gate-Threshold voltage	$V_{th}$	$I_D = -0.1mA, V_{DS} = -3V$	-0.5		-1.5	V
Drain cut-off current	$I_{DSS}$	$V_{DS} = -20V, V_{GS} = 0$			-1	$\mu A$
Gate leakage current	$I_{GSS}$	$V_{GS} = \pm 7V, V_{DS} = 0$			$\pm 1$	$\mu A$
Drain-Source on-resistance	$R_{DS(ON)}$	$V_{GS} = -2.5V, I_D = -10mA$			40	$\Omega$
Forward transfer admittance	$ Y_{fs} $	$V_{DS} = -3V, I_D = -10mA$	15			mS
Input capacitance	$C_{iss}$	$V_{DS} = -3V, V_{GS} = 0, f = 1MHz$		10.4		pF
Output capacitance	$C_{oss}$	$V_{DS} = -3V, V_{GS} = 0, f = 1MHz$		8.4		pF
Reverse Transfer capacitance	$C_{rss}$	$V_{DS} = -3V, V_{GS} = 0, f = 1MHz$		2.8		pF
Turn-on time	$t_{ON}$	$V_{DD} = -3V, I_D = -10mA$ $V_{GEN} = 0 \sim -2.5V$		0.15		$\mu s$
Turn-off time	$t_{OFF}$	$V_{DD} = -3V, I_D = -10mA$ $V_{GEN} = 0 \sim -2.5V$		0.13		$\mu s$

### \*. Switching Time Test Circuit

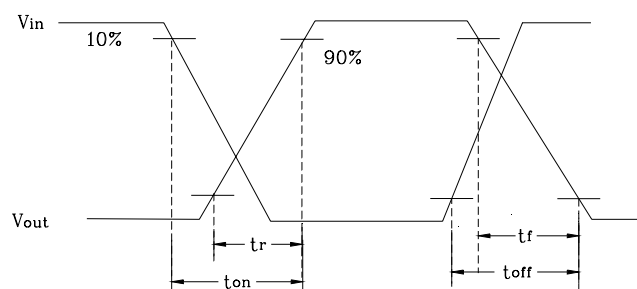
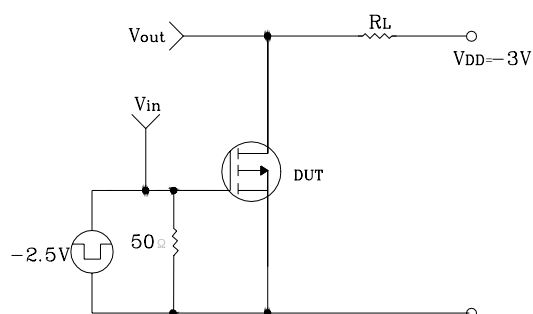

Electrical Characteristic Curves

Fig1 Id - Vds

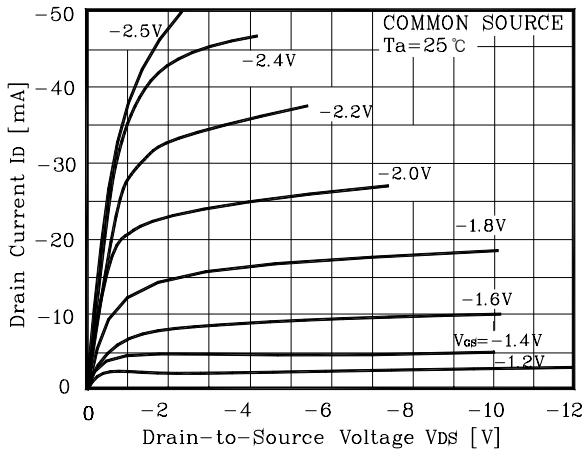

Fig2 Id - Vds

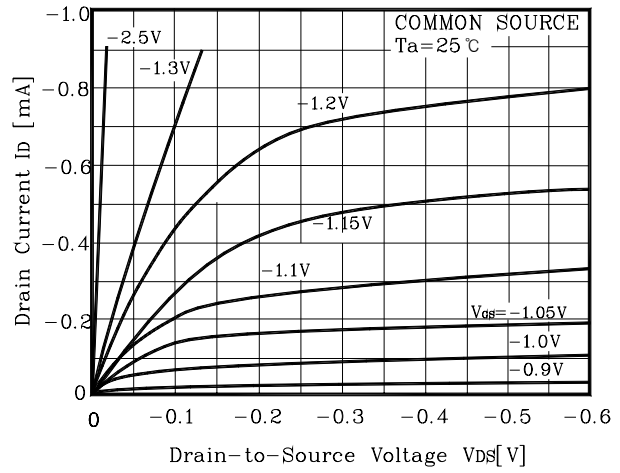

Fig3 IDR - Vds

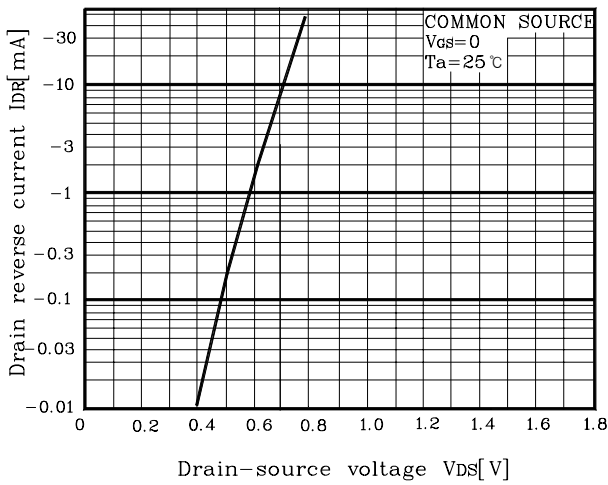

Fig4 Id - Vgs

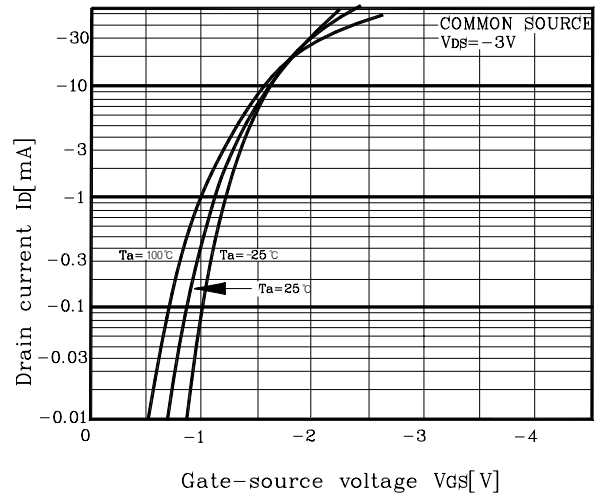

Fig5 | Yfs | - Id

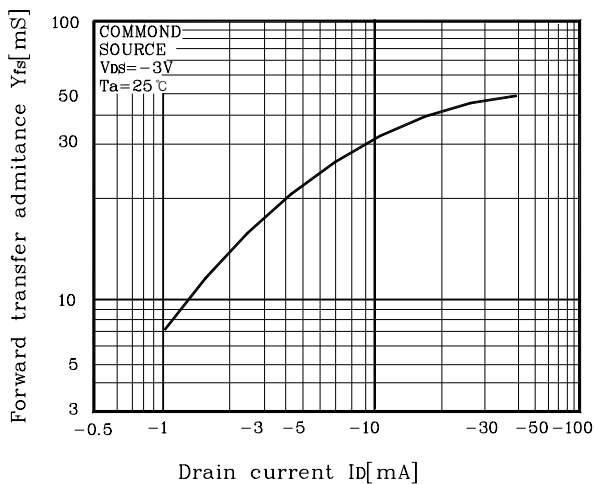
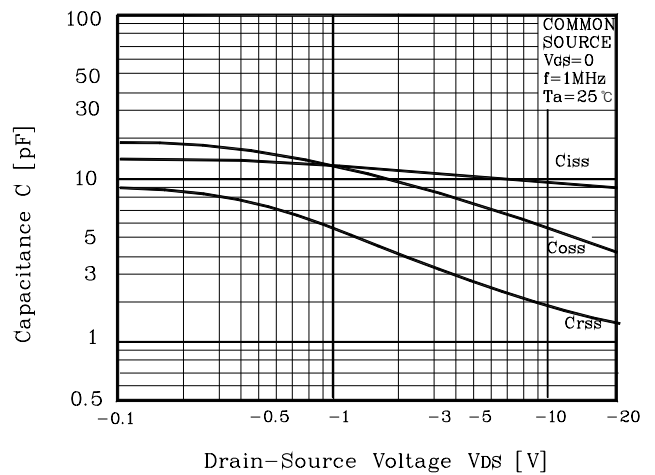
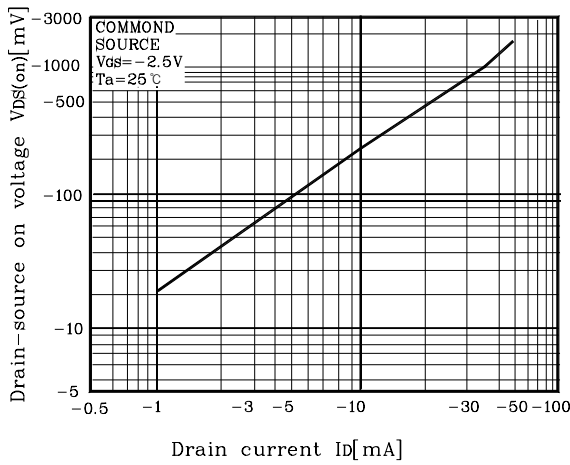

Fig6 C - Vds



**Fig7 VDS(on) - ID**



**Fig8 t - ID**

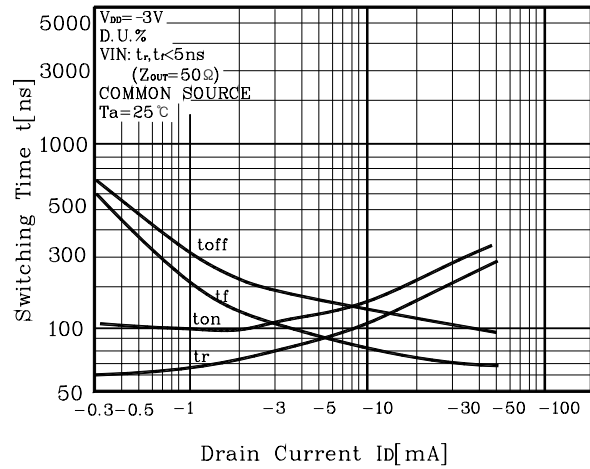

**Fig9 PD - Ta**

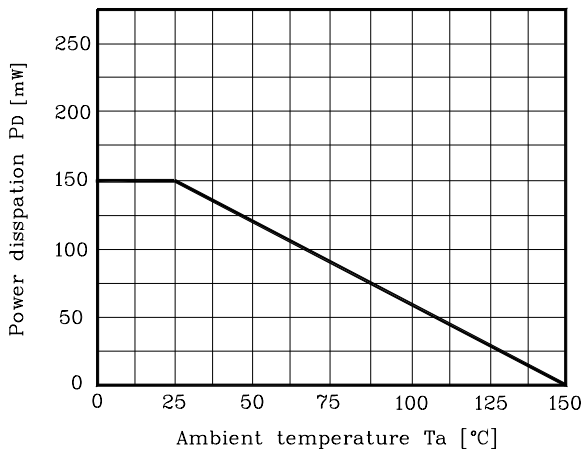

The AUK Corp. products are intended for the use as components in general electronic equipment (Office and communication equipment, measuring equipment, home appliance, etc.).

Please make sure that you consult with us before you use these AUK Corp. products in equipments which require high quality and / or reliability, and in equipments which could have major impact to the welfare of human life(atomic energy control, airplane, spaceship, transportation, combustion control, all types of safety device, etc.). AUK Corp. cannot accept liability to any damage which may occur in case these AUK Corp. products were used in the mentioned equipments without prior consultation with AUK Corp..

Specifications mentioned in this publication are subject to change without notice.